

INSTALLATION AND INSTRUCTIONAL MANUAL PV SERIES

BASE LINE PV SERIES

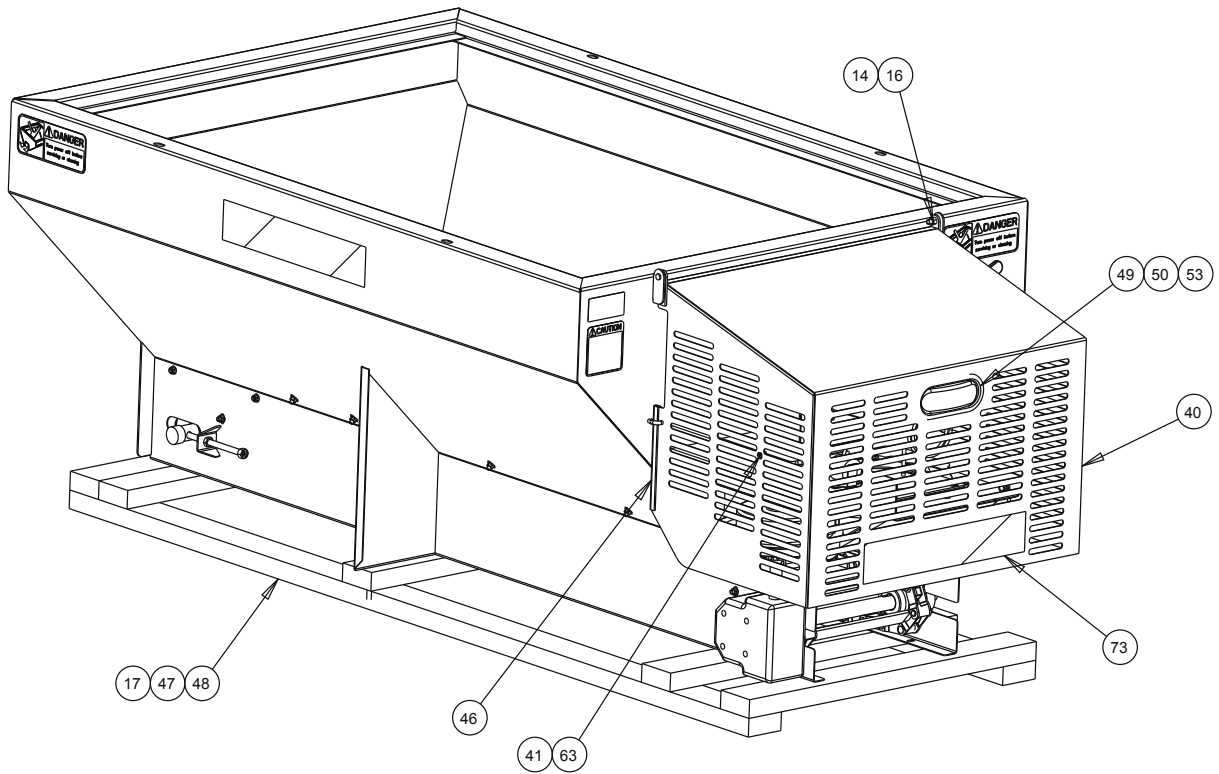

INSTALLATION AND INSTRUCTIONAL MANUAL PV SERIES

BASE LINE PV SERIES

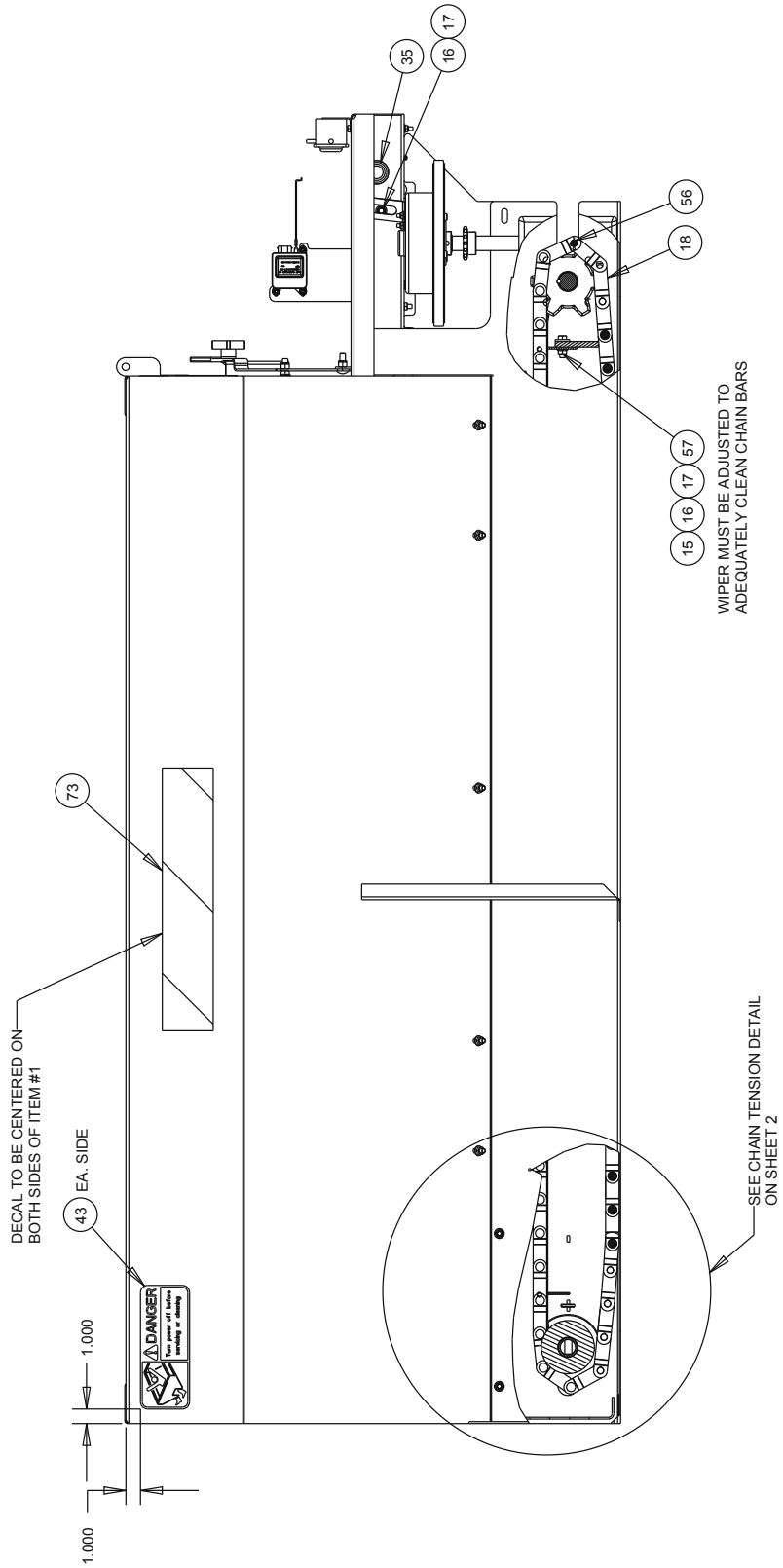

INSTALLATION AND INSTRUCTIONAL MANUAL PV SERIES

BASE LINE PV SERIES

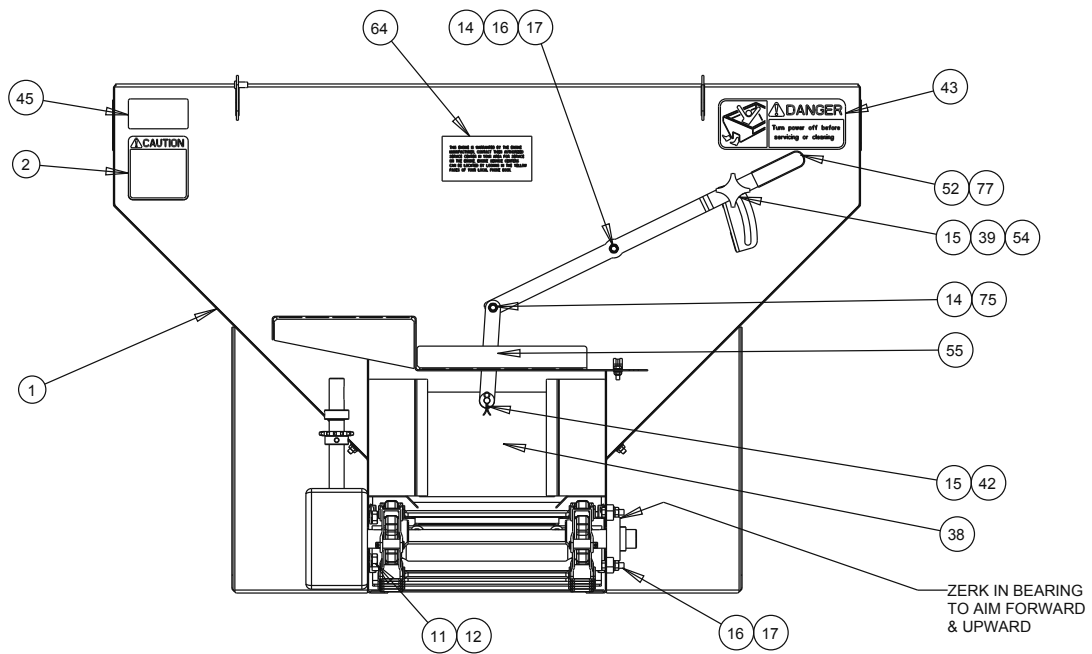

DETAIL, FEEDGATE,
HANDLE ASSEMBLY
& DECALS

INSTALLATION AND INSTRUCTIONAL MANUAL PV SERIES

BASE LINE PV SERIES

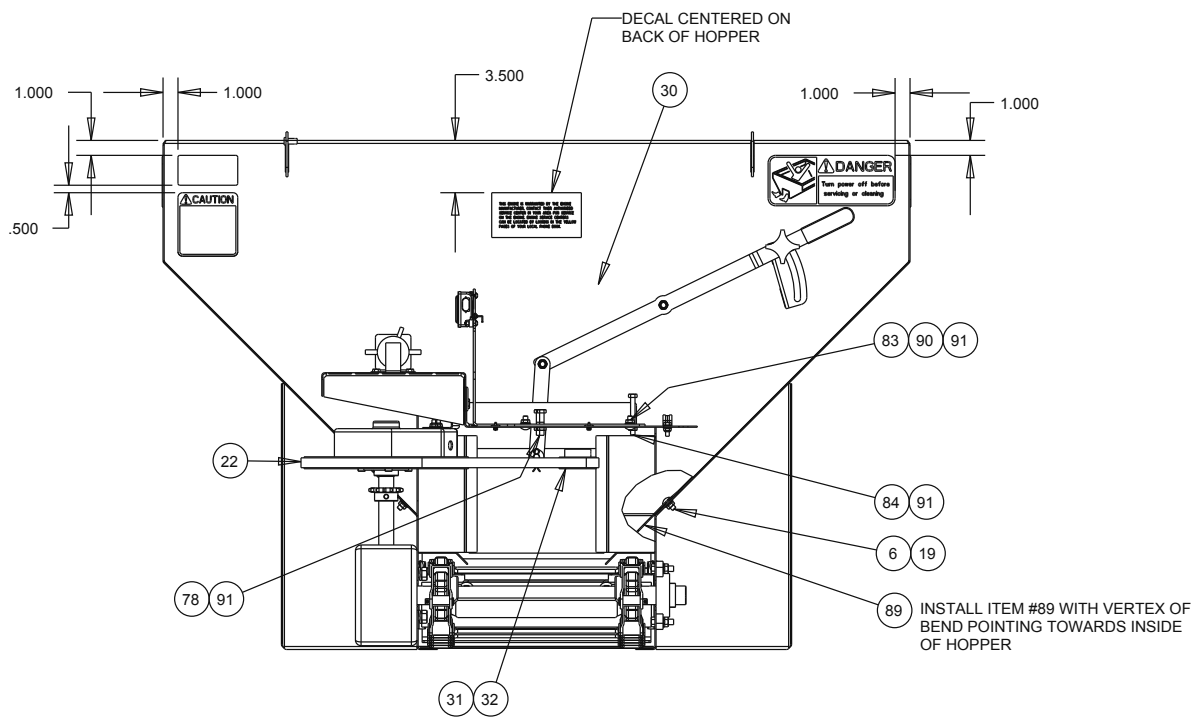

INSTALLATION AND INSTRUCTIONAL MANUAL PV SERIES

BASE LINE PV SERIES

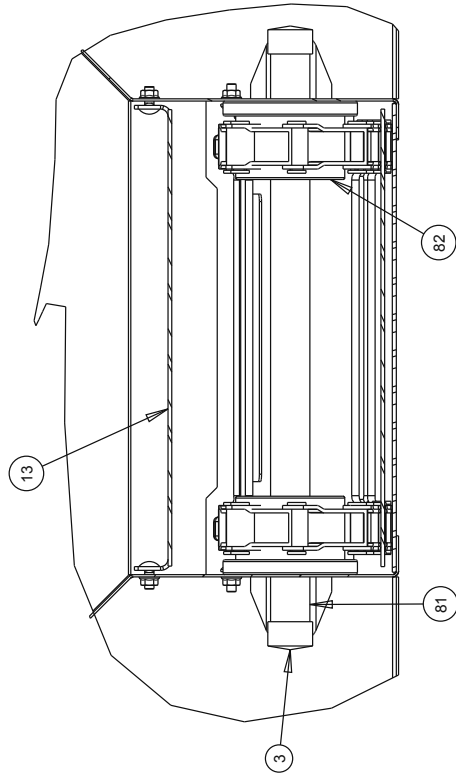
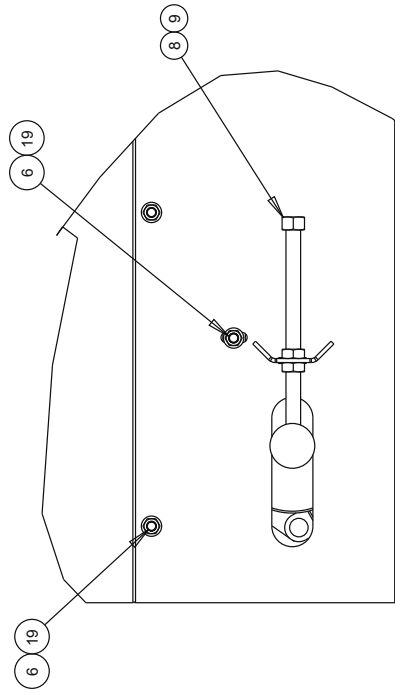

DETAIL, IDLER ASSEMBLY

INSTALLATION AND INSTRUCTIONAL MANUAL PV SERIES

BASE LINE PV SERIES

DETAIL, ACTUATOR &
THROTTLE ASSEMBLY
SCALE .250

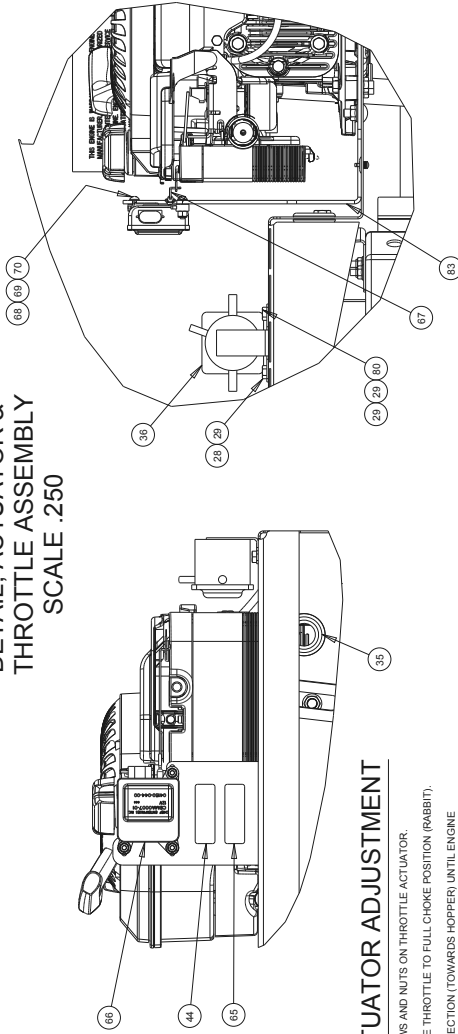

THROTTLE ACTUATOR ADJUSTMENT

1. LOOSEN THREE MOUNTING SCREWS AND NUTS ON THROTTLE ACTUATOR.
2. USING SPREADER CONTROL, MOVE THROTTLE TO FULL CHOKE POSITION (RABBIT).
3. SLIDE ACTUATOR IN CORRECT DIRECTION (TOWARDS HOPPER UNTIL ENGINE LINKAGE HAS MOVED TO FULL CHOKE. DO NOT PUT EXCESSIVE FORCE ON LINKAGE ROD.
4. TIGHTEN THREE MOUNTING SCREWS AND NUTS.
5. TEST RUN ENGINE FOR FULL CHOKE ENGAGEMENT.

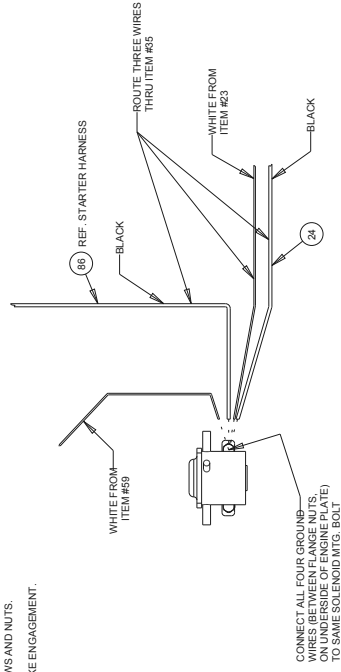

DETAIL, GROUND WIRING
SCALE .250

INSTALLATION AND INSTRUCTIONAL MANUAL PV SERIES

BASE LINE PV SERIES

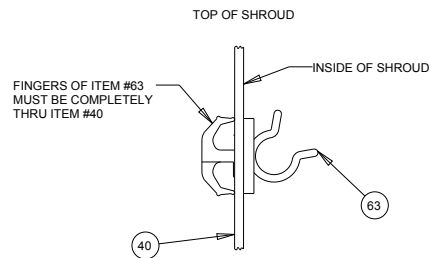

DETAIL, PROP ROD
CLAMP ASSEMBLY
SCALE 1.125

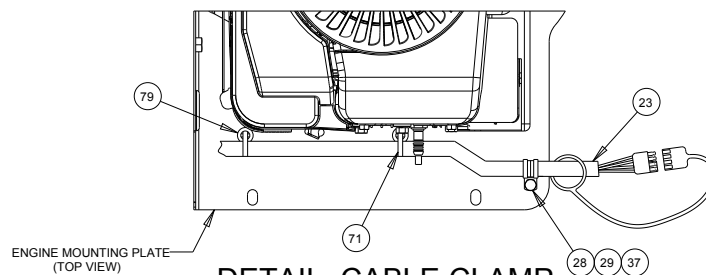

DETAIL, CABLE CLAMP
SCALE .375

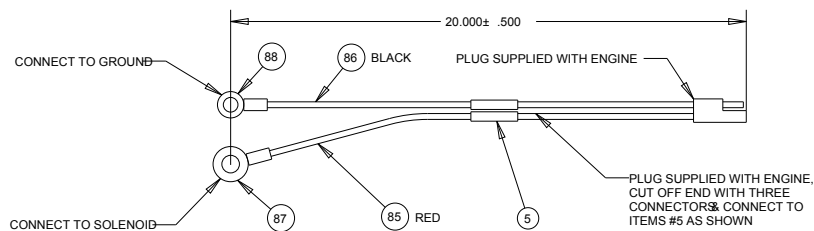

DETAIL, STARTER HARNESS
SCALE .500

INSTALLATION AND INSTRUCTIONAL MANUAL PV SERIES

BASE LINE PV SERIES

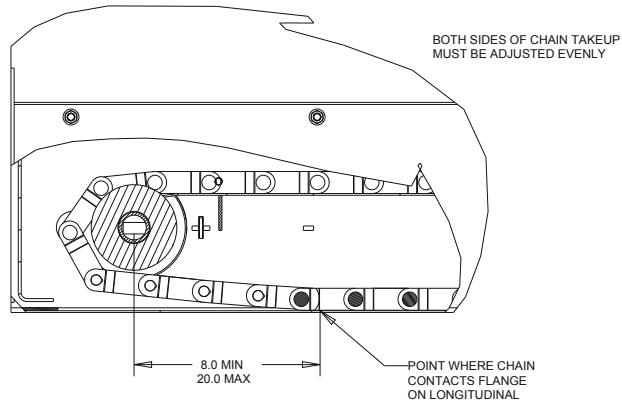

DETAIL, CHAIN TENSION
SCALE 0.250

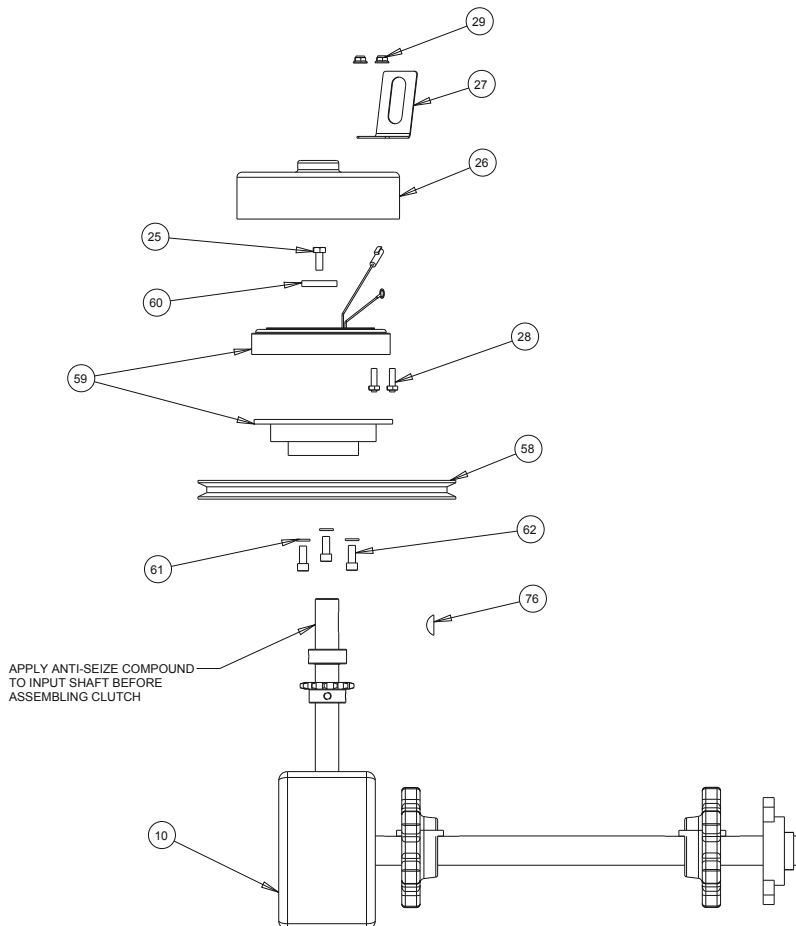

DETAIL, CLUTCH ASSEMBLY
SCALE 0.250

INSTALLATION AND INSTRUCTIONAL MANUAL PV SERIES

BASE LINE PV SERIES

ITEM	PART NUMBER	DESCRIPTION	QTY
29	62690	NUT, 1/4" SER FLANGE	5
28	62189	BOLT, 1/4" X 3/4" HH	4
27	64415	RETAINER, CLUTCH	1
26	62268	COVER, CLUTCH	1
25	62752	BOLT, 5/16 X 3/4 HH	1
24	62944	WIRE, REM. BATT. NEGATIVE	1
23	64086	CABLE, SPREADER CONTROL	1
22	62940	V-BELT, BX-46	1
21	64416	FORM, CONVEYOR FLOOR	1
20	62106	BOOT, ALT CABLE	2
19	62640	BOLT, 5/16 X 3/4 CA	18
18	64244	WELD, DRAG CHAIN	1
17	62743	NUT, 3/8" SER FLANGE	8
16	62695	BOLT, 3/8" X 1 1/4" HH	7
15	63565	FLATWASHER, 3/8"	4
14	62638	LOCKNUT, 3/8" VINYL	3
13	63264	FORM, GUARD, CONVEYOR	1
12	62772	LOCKWASHER, 1/2"	4
11	62750	BOLT, 1/2" X 3/4" HH	4
10	63117	SUB- Y, GEARBOX	1
9	62336	NUT, 1/2" HEX JAM	4
8	62304	WELD, TAKEUP BOLT	2
7	64417	PV356 SHIPPING CARTON	1
6	62641	NUT, 5/16 SER FLANGE SS	18
5	64418	CONNECTOR, BUTT	2
4	64419	WIRE, BROWN JUMPER 4"	1
3	64064	CAP, IDLER	2
2	62007	DECAL, CAUTION	1
1	64420	WELD, HOPPER	1

INSTALLATION AND INSTRUCTIONAL MANUAL PV SERIES

BASE LINE PV SERIES

ITEM	PART NUMBER	DESCRIPTION	QTY
59	61176	CLUTCH, ELECTRIC	1
58	61161	PULLEY, DRIVEN	1
57	62354	WIPER, CHAIN	1
56	61174	PIN, CONNECTOR W/ COTTER	2
55	62270	BAR, PIVOT	1
54	62746	BOLT, 3/8" X 3/4" CA SS	1
53	62714	LAMP, STOP	1
52	63828	FORM, FEEDGATE HANDLE	1
51	63880	OIL, MOTOR	0.156
50	62715	GROMMET, MTG.	1
49	62364	CABLE, LIGHT POWER	1
48	62657	BOLT, 3/8" X 4" CA SS	2
47	64413	SKID, PV 6'	1
46	62656	TRIM, VINYL	2
45	62571	DECAL, SERIAL NUMBER	1
44	62768	DECAL, GASOLINE ONLY	1
43	62009	DECAL, DANGER	3
42	62691	PIN, 1/8" X 1" COTTER SS	1
41	61215	ROD, PROP	1
40	64414	WELD, SHROUD	1
39	61169	KNOB, HAND	1
38	66822	WELD, FEEDGATE	1
37	62652	CLAMP, CUSHIONED	1
36	64167	SOLENOID	1
35	62765	GROMMET	1
33	62943	WIRE, REM. BATT. POS.	1
32	62938	PULLEY, DRIVER	1
31	64203	KEY, 3/16" X 1" SQ	1
30	64245	ENGINE, 190CC B&S QUANTUM	1

INSTALLATION AND INSTRUCTIONAL MANUAL PV SERIES

BASE LINE PV SERIES

ITEM	PART NUMBER	DESCRIPTION	QTY
79	64411	HOLDER, NYLON TIE	2
78	62273	BOLT, 5/16" X 1 1/2" HH	2
77	64164	COVER, FEEDGATE HANDLE	1
76	61201	KEY, WOODRUFF	1
75	62813	BOLT, 3/8" X 1 1/4" CA	1
74		P, INSTR. MANUAL	1
73	63156	DECAL, BRAND Meyer	3
72	64412	P, SPINNER PV INT.	1
71	62183	TIE, NYLON	5
70	62650	LOCKNUT, 8-32 VINYL SS	3
69	62651	FLATWASHER, #8 SS	3
68	62649	SCREW, 8-32 X 3/4" PR SS	3
67	62720	LINKAGE, HONDA THROTTLE	1
66	63165	ACTUATOR, 12V	1
65	62643	DECAL, FUEL SHUT OFF	1
64	62644	DECAL, ENGINE WARRANTY	1
63	62725	CLAMP, PROP ROD	1
62	62634	SCREW, 5/16" X 5/8" SH CAP	3
61	63009	LOCKWASHER, 5/16"	3
60	63103	FLATWASHER, CLUTCH RETAINER	1

INSTALLATION AND INSTRUCTIONAL MANUAL PV SERIES

BASE LINE PV SERIES

ITEM	PART NUMBER	DESCRIPTION	QTY
91	63310	NUT, 5/16" SER FLANGE	7
90	63305	BOLT, 5/16" X 3/4" CA	4
89	64405	FORM, CHAINSHIELD	2
88	64406	TERMINAL, 1/4" RING	1
87	64407	TERMINAL, 5/16" RING	1
86	64408	WIRE, 12 GA BLACK	0.75
85	64409	WIRE, 12 GA. RED	0.75
84	63249	BOLT, 5/16" X 2 1/2" HH	1
83	64410	ADAPTER, ENGINE	1
82	64063	ROLLER, POLY	2
81	64062	SHAFT, IDLER	1
80	63586	BOLT, 1/4" X 1" HH	1
ITEM		DESCRIPTION	QTY
7	64417		
44	62768	DECAL, GASOLINE ONLY	
51	63880		
65	62643	DECAL, FUEL SHUT OFF	
72	64412		
74		INSTR. MANUAL SEE B/M	