

# RTJ - SERIES REPLACEABLE TAILGATE SPREADER for One Ton Dump Bodies

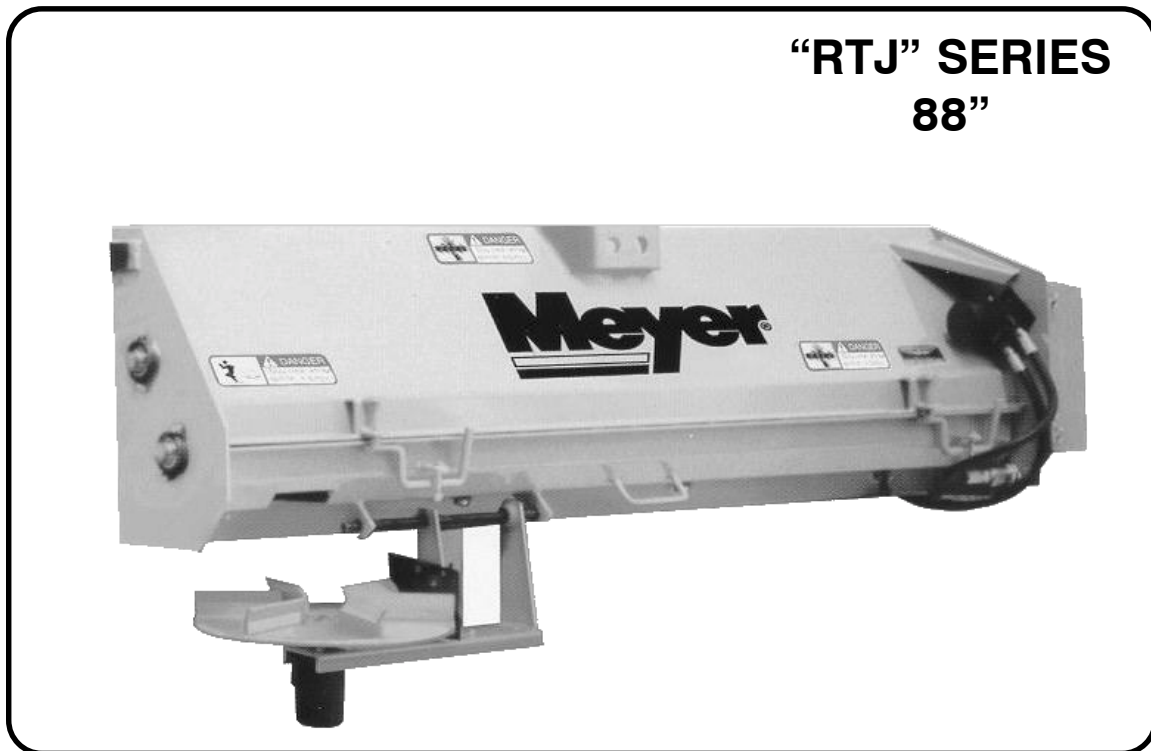

## SERVICE MANUAL

Meyer Products reserves the right, under its continuing product improvement program, to change construction or design details, specifications and prices without notice or without incurring any obligation.

# THE BEST SAFETY DEVICE IS A CAREFUL OPERATOR!

## SAFETY ALERT SYMBOL



**THIS SYMBOL MEANS ATTENTION!  
BECOME ALERT!  
YOUR SAFETY IS INVOLVED!  
PLEASE READ AND UNDERSTAND COMPLETELY BEFORE DOING!**

### SAFE EQUIPMENT INSTALLERS <sup>AND</sup> OPERATORS:



**TURN OFF ALL POWER BEFORE PERFORMING ANY SERVICE OPERATIONS**

- FOLLOW RECOMMENDED OPERATING PROCEDURES.
- KEEP EQUIPMENT IN SAFE OPERATING CONDITION AT ALL TIMES.
- RECOGNIZE AND AVOID HAZARDS WHILE OPERATING, SERVICEING AND MAINTAINING EQUIPMENT.



### CAUTION

1. KEEP ALL SHEILDS IN PLACE.
2. MAKE CERTAIN EVERYONE IS CLEAR BEFORE STARTING MACHINE OR MOVING VEHICLE.
3. KEEP HANDS, FEET, AND CLOTHING AWAY FROM ALL POWER DRIVEN PARTS.
4. DISENGAGE p.t.o., SHUT OFF HYDRAULIC VALVE AND SET PARKING BRAKE BEFORE LEAVING OPERATOR'S POSITION. MAKE SURE ALL MOVEMENT HAS STOPPED BEFORE SERVING OR UNCLOGGING MACHINE.
5. USE FLASHING LIGHTS WHEN OPERATING MACHINE.
6. MAKE SURE MACHINE IS SOLIDLY SUPPORTED WHEN IT IS BEING MOUNTED, DISMOUNTED, OR STORED.



### DANGER

**Stay clear while spinner is turning**



### DANGER

**Turn off power before servicing.**

**INDEX**  
**FOR**  
**“RTJ” SERIES SPREADERS**

	PAGE NO.
SAFETY INSTRUCTIONS .....	2
INDEX .....	3
MOUNTING INSTRUCTIONS .....	4 thru 8
“RTJ” PARTS LIST .....	9 - 10
PLUMBING DIAGRAM / INSTALLATION NOTES .....	11 - 12
HOSE IDENTIFICATION .....	13
VALVE INSTALLATION / PARTS LIST .....	14 - 15
OPERATING INSTRUCTIONS .....	16 - 17
DUAL FLOW VALVE & PARTS LIST .....	18 - 19
MAINTENANCE INFORMATION .....	20
TROUBLE SHOOTING .....	21
SPINNER PARTS LIST .....	22
WARRANTY .....	23
NAME PLATE INFORMATION .....	BACK COVER

## MOUNTING INSTRUCTIONS

1. Remove dump body tailgate.
2. Position spreader against rear of dump body with trough lip approximately 1/4" above dump body floor, temporarily clamp spreader in place
3. Pin upper hinge bracket into offset hinge of dump body and position against spreader ends. (Spacers may be required for proper alignment.) Tack weld in place. (See Figure 1 pg. 5)
4. Clamp latch pin in tailgate latch on dump body. Position against endplate of spreader. Square up with endplate and tack weld in place.  
Note: Spreader is designed to fit dump bodies with 78" inside width without the use of extenders. Dump bodies with inside widths greater than 78" will require that furnished extenders be bolted in place with furnished bolts. Adjust extenders utilizing slots for tight fit against rear of dump body. (See Figure 2 pg.5)

If extenders are required, upper hinge brackets will likely require being welded to the extenders.

5. Follow similar procedures for opposite end of spreader.
6. Remove spreader and weld hinge brackets and latch pins solidly in place.
7. Cut off pins to desired length.
8. The spinner assembly is next hung on its' hinge pin and the parallel linkage installed. See instructional drawing included in this manual on page 5.

The frame bar 62413 is welded to the outside of the truck's main frame side rail - left hand side- and positioned so that the center line of the hole is exactly 11-1/2" below the dump body hinge pin center line on the vertical line.

If this point cannot be made due to interference from a spring hanger or unusual dump body design, or other reason, then the following steps must be taken:

A. Locate the hinge point in the frame bar ahead and/or below the point as described above but as close as possible to that point.

B. Modify the spinner frame hinge point by cutting off the hinge lug on the bottom and moving it, or adding another ahead and/or below the same distance and direction as the hinge point in the frame bar was moved.

C. Install the two linkage rods (62415), one in the spinner lug and the other in the frame bar.

While keeping the spinner assembly level and centered between extreme left and right positions, weld linkage rods solidly at lapped joint.

## POSITIONING LATCH PIN

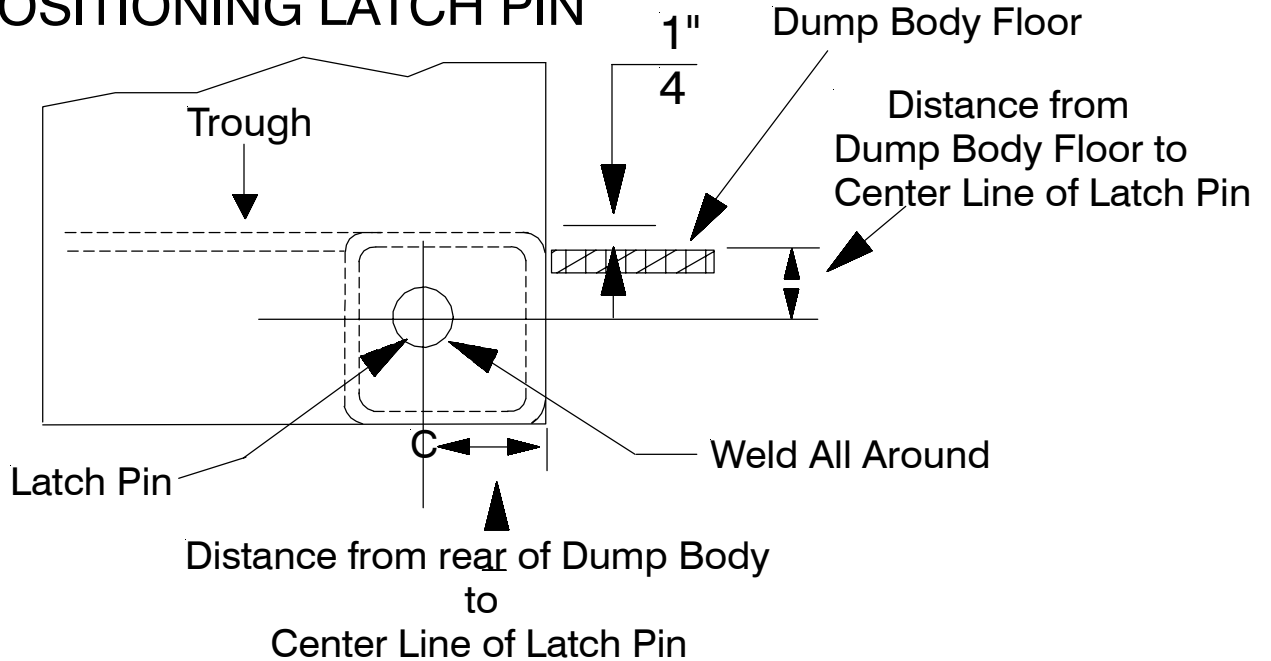

**Figure 1**

*Note: Gussets supplied to be added as needed when Extenders are used.*

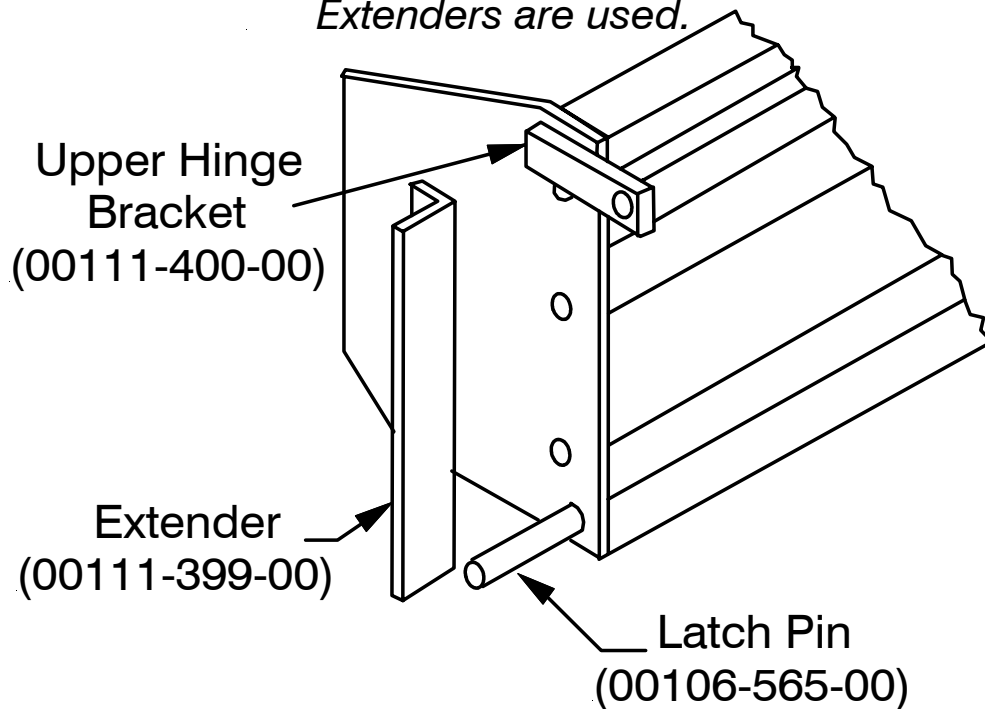

**Figure 2**

**Note: Gussets supplied to be added as needed when Extenders are used.**

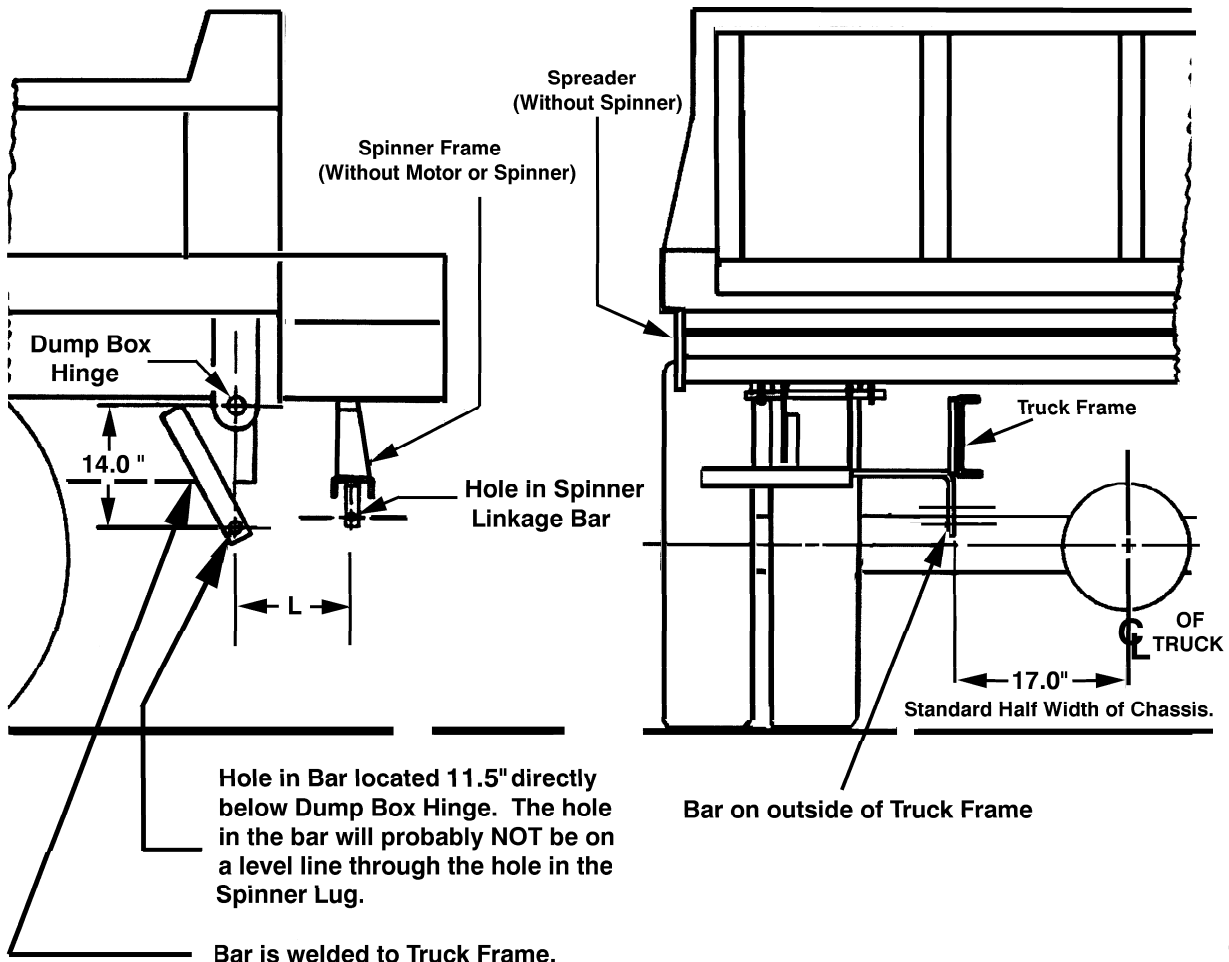

**62413**

Note: If hole under Spinner Frame cannot be located as shown, modifications must be made to spinner frame.

## Mounting Instructions for Thru - Shaft Hydraulic Pump, Reservoir, Filter and Hoses

(All standard truck and hydraulic spreader plumbing installations)

**Note:** Instructions for PTO mounted and front mounted pumps will be furnished upon request.

**General:** The Thru - Shaft pump, valve, reservoir and filter with mounting brackets and fasteners may be used on most any truck with an existing transmission PTO and continuously operating dump hoist pump installation.



**Caution:** If dump body is raised for easier pump installation, it must be blocked securely before disconnecting dump hoist.

### Important:

1. Taking time to plan location of major hydraulic components will save time in further plumbing operations.
2. All pipe fittings should be cleaned before installing, and all other hydraulic components to be kept as clean as possible during assembly.
3. Check rotation of PTO for proper pump mounting.
4. Pump must be mounted so shaft rotates in direction of arrow.
5. Two U - joints (one standard type, and one slip type) must be used on ends of each piece of shafting installed in drive train.
6. Yokes on U - joints must be in phase (time) for smooth operation. Caution: All set screws in U - joints must be tight and properly safety wired.

### Pump Installation:

1. Check PTO RPM with truck engine at 2000 RPM. This reading should be in the operating range of 1200 to 1500 RPM. If this range cannot be achieved it will be necessary to change the PTO accordingly.
2. Pump is installed between transmission PTO and existing hoist pump. Remove existing shaft connecting PTO to hoist pump.
3. Determine best location for pump, and mount on bracket. (follow general instructions below).
  - a. Keep in mind location of suction hoses, pressure hoses and valve.
  - b. Pump drive shafting should be in as straight a line as possible not to exceed 15° bend at any U - joint.
  - c. Pump drive shafting may be cut to length as needed.
  - d. If hoist pump is swivel type that moves as dump body is raised or lowered, distance should be allowed between new pump and hoist pump for workable

- e. Short leg of pump bracket is bolted inside truck chassis frame.
- f. Pump is bolted to long leg of bracket using holes which best align with pump.
- g. Mounting brackets may be rebent as needed, and any excess cut off.
- h. Furnished brace may be welded as needed for added support on pump bracket.

**Note:** Moving of hoist pump may be required, follow above general instructions as needed for reinstallation of hoist pump.

### **Reservoir and Filter Installation:**

1. Locate reservoir as close to pump as possible.
2. Reservoir may be located inside or outside of truck frame. (Ease in filling reservoir is important).
3. Tank mounting brackets must be bolted to truck frame.
4. 3/4" plug at bottom of reservoir is drain.
5. Filter is screwed directly onto reservoir with cartridge down.
6. Oil must flow through filter in direction of arrow on filter.
7. Screw plug, or optional guage into filter.

### **Valve Installation:**

1. Consider final location of valve before assembling; depending upon location of valve, pipe fittings in valve body may require repositioning.
2. Locate valve in truck cab in position convenient for driver, and for hosing or piping through floor board under driver's seat.
3. Valve may be operated in any position desired.

### **Hose Installation:**

Enough hose and fittings are furnished in the various kits for standard spreader installation. Refer to the complete hydraulic plumbing diagram included in this manual for hosing all mounted components, (page 8).

### **Note:**

Spinner assemblies on tailgate spreaders must be in extreme left position when installing hoses between spinner motor and quick disconnects at rear of truck chassis.



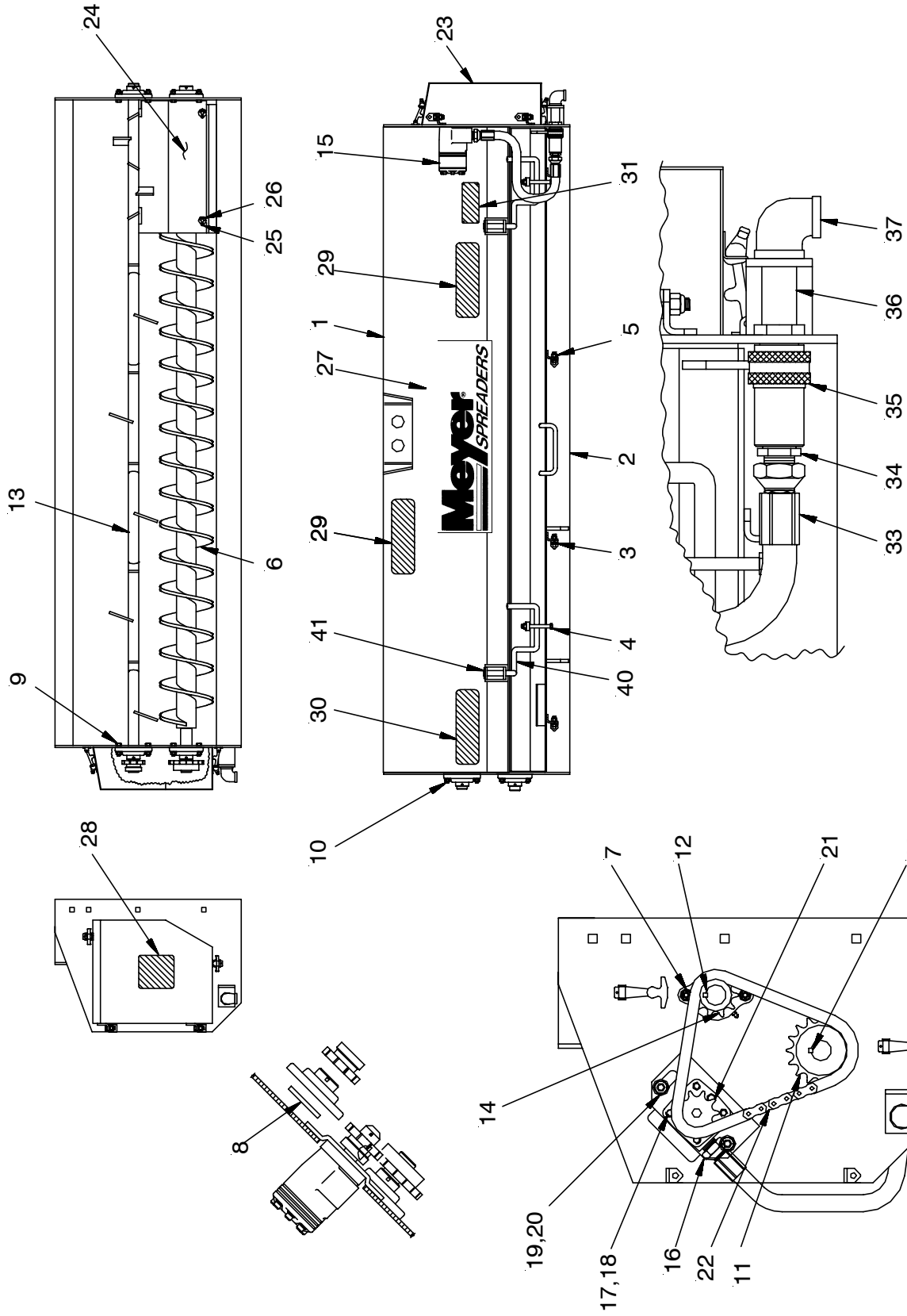

## RTJ Replaceable Tailgate Spreader

### Parts List

Item	Part No.	Qty.	Description
1	62488	1	Weldment, Trough
2	62489	1	Weldment, Bottom Door
3	04003 003 10	6	Bolt 3/8 x 1H.H.
4	04003 003 10	2	Bolt 3/8 x 3-1/2 H.H.
5	20305	8	Locknut 3/8 w/ Nylon Insert
6	62490	1	Wedment, Auger
7	62400	4	Bearing, 1-1/4"
8	62480	4	Washer, 1-1/4" Felt
9	04003 003 05	8	Bolt 3/8 x 1-1/2 H.H.
10	04003 806 02	8	Nut 3/8 Flange
11	62491	1	Sprocket, 60B16
12	60421	2	Key, 1/4 x 1-1/4" SQ.
13	62492	1	Weldment, Agitator
14	62493	1	Sprocket, 60B10
15	04101 036 00	1	Motor, Hydraulic
16	00106 341 00	1	Offset, Motor Mounting
17	04003 003 01	4	Bolt 3/8 x 3/4 H.H.
18	20327	4	Lockwasher 3/8
19	04003 034 01	2	Bolt 1/2 x 1 C.
20	04003 806 03	2	Nut 1/2 Flange
21	62475	1	Weldment, Sprocket & Coupling
22	62495	1	Chain, Roller
23	00111 395 00	1	Weldment, Chain Cover
24	62496	1	Cover, Formed Flow
25	04004 002 08	2	Flatwasher 3/8
26	04010 004 01	2	Pin, 5/32 x 1 Cotter
27	62497	1	Decal, RTJ
28	04045 045 00	1	Decal, Caution
29	62515	2	Decal, Danger (Auger)
30	62006	1	Decal, Danger (Spinner)
31	21932	1	Decal, Serial
33	04120 020 01	1	Hose, 1/2 x 28" (1) Wire
34	04110 016 04	1	Bushing, 3/4 x 1/2 Red.
35	62514	1	Disconnect, 3/4 Quick
36	04110 028 05	1	Nipple, 3/4 x 3"
37	04110 008 04	1	Elbow, 3/4 x 1/2 Red.
	00001 775 00	1	Package, Safety Decal
40	00113 800 00	2	Door Latch Handle
41	04003 807 12	2	Lockunt, 5/8 Centerloc

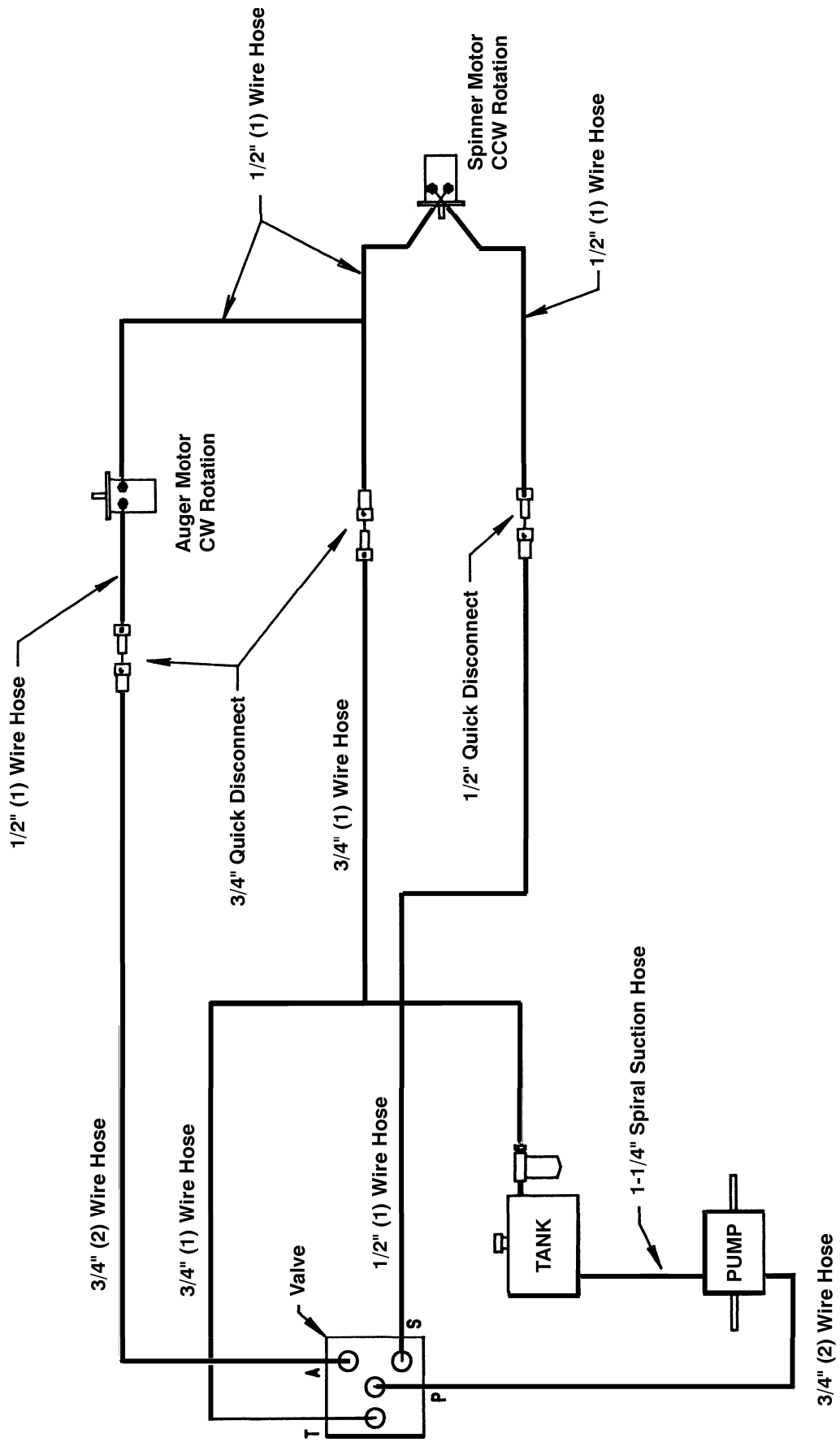





## INSTALLATION NOTES

1. HYDRAULIC COMPONENTS SHOULD BE KEPT AS CLEAN AS POSSIBLE DURING ASSEMBLY OPERATIONS.
2. GALVANIZED PIPE AND FITTINGS MUST NOT BE USED, FLAKING OF GALVANIZED MATERIAL CAN DAMAGE HYDRAULIC COMPONENTS.
3. PIPE JOINT SEALANT. COMPATIBLE WITH HYDRAULIC OIL, MUST BE USED ON ALL SCREWED FITTINGS.  
(TEFLON TAPE IS NOT RECOMMENDED)
4. SUFFICIENT HOSE SHOULD BE ALLOWED FOR RAISING DUMP BODY WITHOUT KINKING OR STRETCHING HOSE.
5. HOSE SHOULD BE PROTECTED WHERE SEVERE WEAR MAY BE CAUSED BY VIBRATION OR SLIDING MOVEMENT.
6. LONG HOSE RUNS SHOULD BE SUPPORTED BY WIRE TIE OR CLAMPS
7. (AUGER. SPINNER)  
PRESSURE AND RETURN HOSES MAY BE REVERSED FOR PROPER MOTOR ROTATION.
8. THREE HOSE LINES TO REAR OF TRUCK MAY BE INSTALLED INSIDE OF TRUCK FRAME. UNDER DUMP BODY FLOOR. AND SECURED IN PLACE.
9. USE HOSE MANUFACTURERS RECOMMENDED REUSEABLE HOSE END FITTINGS.
10. TO ELIMINATE HOSE TWISTING. ALLOW HOSE END CLAMP TO REMAIN LOOSE UNTIL FITTINGS ARE TIGHT

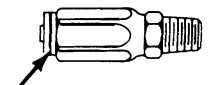
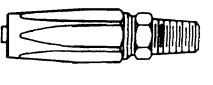
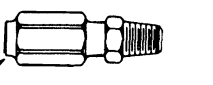
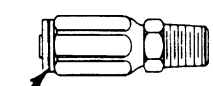
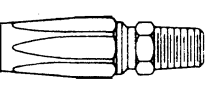
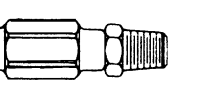
# HOSE END ASSEMBLY INSTRUCTIONS

## FITTING IDENTIFICATION

	GATES	AEROQUIP	PARKER
$\frac{1}{2}$ " 1 WIRE	 Single Groove	 Plain Machining	 Plain Shoulder
$\frac{3}{4}$ " 1 WIRE	 Single Groove	 Plain Machining	 Plain Shoulder
$\frac{3}{4}$ " 2 WIRE	 Double Groove	 Large Groove	 Machine Notches

## HOSE IDENTIFICATION

(Locate S.A.E. number on hose as shown)

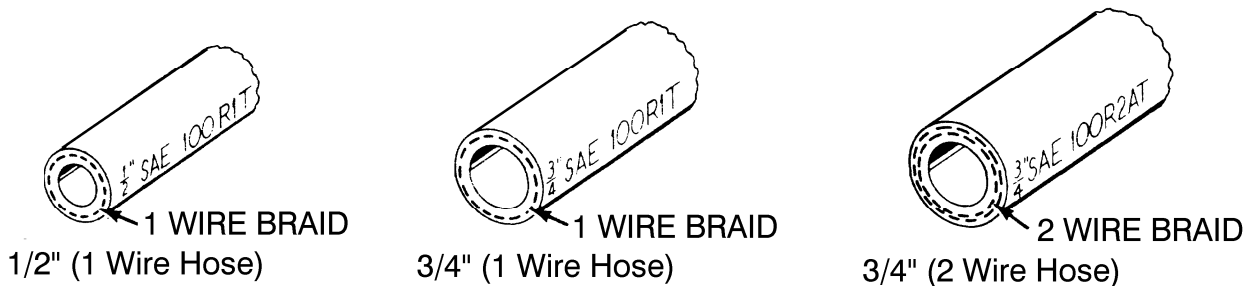

## ASSEMBLY INSTRUCTIONS

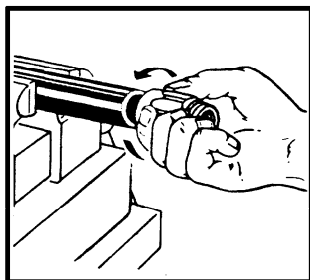

### Step 1

Liberally oil hose cover with lube oil, place hose in a vise just tight enough to prevent it from turning. Screw socket onto hose counter-clockwise until it bottoms. Back off 1/2 turn.

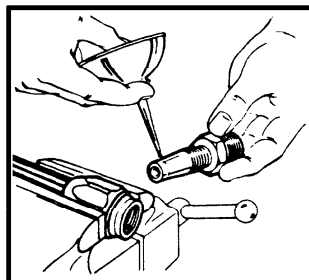

### Step 2

Oil nipple threads and inside of hose liberally.

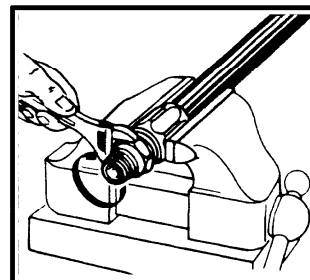

### Step 3

Screw nipple clockwise into socket and hose. Leave 1/32" to 1/16" clearance between nipple hex and socket. Clean and inspect all assemblies. Disassemble in reverse order.

## DUAL FLOW VALVE/STAND INSTALLATION INSTRUCTIONS

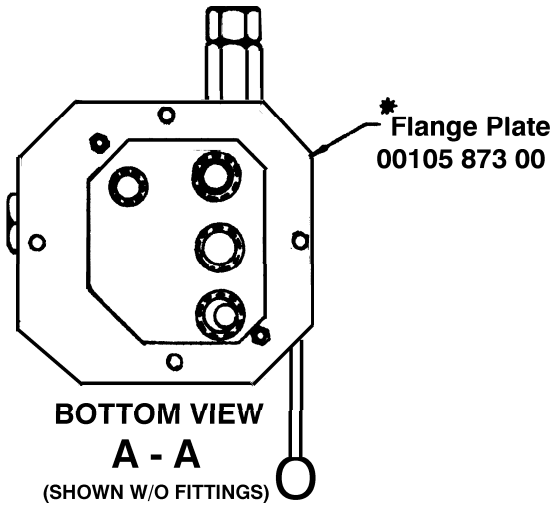

1. **IMPORTANT:** A pipe joint sealant compatible with hydraulic oil must be applied to all screw fittings. (Teflon Tape Sealant Is Not Recommended)
2. Hose ends connected to flow valve must be of the "swivel" type.
3. **CAUTION:** Over tightening of the fittings in flow valve may cause damage to valve body.
4. Approximately 8" of hose slack must be realized between the flow valve and valve stand after the flow valve has been completely plumbed. If this condition does not exist after the plumbing has been completed, removal of valve will require hoses to be removed at opposite end of valve.

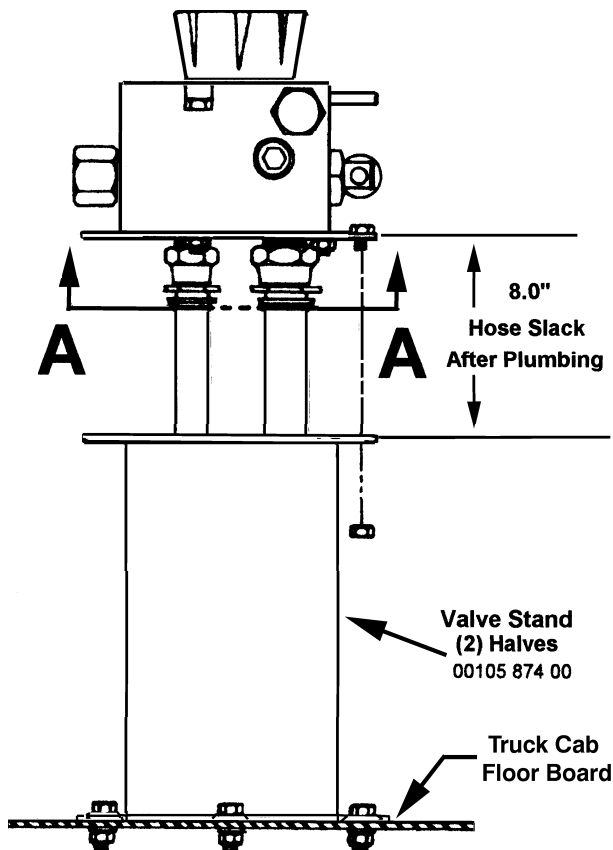

5. Assembly of valve on stand:
  - A. Cut a 5" x 5" square opening in floor board of truck where the valve stand is to be located.
  - B. Bolt valve stand halves together forming a "box" over the 5" x 5" square opening. NOTE: When bolting valve stand halves in place, make sure holes in flanges align with holes in flange plate.\*
  - C. Bolt flange plate to VALVE (Use (2) 1/4" x 3 1/2" bolts, lockwashers, etc.)
  - D. Insert hoses through floor opening and valve stand and connect appropriate hoses (see instruction #1 thru #4) to flow valve.
  - E. Bolt flange plate to valve stand flanges.
6. Valve may be operated in any position.
7. Valve on-off lever should be in off position when not in use or when spreader is removed from truck.

## VALVE STAND KIT

(00001 692 00)

### Parts List

PART NO.	QTY.	DESCRIPTION
00105-874-00	2	Valve Stand (Upright)
00105-873-00	1	Flange Plate Valve Stand
04003-001-10	2	1/4" x 3" H.H. Bolt
04003-001-05	8	1/4" x 1.0" H.H. Bolt
62478	10	1/4" H.H. Nut
20325	10	1/4" Lockwasher

## HYDRAULIC KIT (8-11' Dump Body)

(00001 206 00)

### Parts List

PART NO.	QTY.	DESCRIPTION
04120-003-01	2	Hose, 1/2" x 48" x (1) Wire
04120-003-12	2	Hose, 1/2" x 60" x (1) Wire
04120-026-04	1	Hose, 1/2" x 15' x (1) Wire
04120-014-04	1	Hose, 3/4" x 15' x (1) Wire
04120-033-01	1	Hose, 3/4" x 25' x (2) Wire
60209	2	Quick Disconnect, 1/2"
62514	2	Quick Disconnect, 3/4"
62419	2	Reuseable Hose End, 1/2"
62420	6	Reuseable Hose End, 3/4"
62421	4	Reuseable Hose End, 3/4"
62422	1	Swivel Adapter, 1/2" (F) x 1/2" (M)
62431	4	Swivel Adapter, 3/4"
04110-016-05	1	Bushing, 1" x 3/4" Reducing
04110-016-04	1	Bushing, 3/4" x 1/2" Reducing
04110-028-01	1	Nipple, 3/4" Close
21387	1	Tee, 3/4"
21454	1	Tee, 3/4" x 1/2" x 1/2" Reducing
04110-027-05	1	Nipple, 1/2" x 3"
04110-004-04	1	Elbow, 1/2" 90 Degree
04110-006-04	1	Elbow, 1/2" 90 Degree Street

# OPERATING INSTRUCTIONS FOR ALL TAILGATE SPREADERS HAVING SEPARATE MOTORS FOR AUGER AND SPINNER



## CAUTION!

1. When starting up new equipment, be sure every one is **standing clear, watch** for anything that may require shutting system down.
2. Be sure lever on valve is moved completely to “off” position before working in or around spreading equipment.

## Initial Start Up

1. Fill reservoir about three-fourths full with high grade nonfoaming hydraulic oil. KEEP OIL CLEAN.
2. Move valve on-off lever to “off” position.
3. Open auger and spinner knobs on valve.
4. Engage PTO and allow hydraulic oil to circulate several minutes to warm up.
5. Move valve on-off lever to “on” position.
6. Check entire hydraulic system for leaks
7. Examine auger and spinner to see if they are functioning properly.
8. Shut off power to hydraulic system.
9. Refill reservoir to three-fourths full.
10. Hydraulic system is ready for use.

## Preparing Spreader For Use

1. Start truck engine and allow hydraulic system to warm up by shutting off spinner and auger knobs and moving on-off lever to “on” position.
2. Position cover plate vertically and secure with locking brackets. (For under tailgate models)
3. Open dump body tailgate from bottom as wide as possible but not bearing against cover plate, set the stop chains. (For under tailgate models)
4. Loosen spinner clamp and slide spinner assembly to far left, and tighten clamp. (Position for spreading three or four lane highway from right lane)
5. Spread small amount of material to determine placement of material at various spinner and auger speeds in this far left position.
6. Loosen spinner clamp and slide spinner assembly to far right and tighten clamp. (Position for spreading behind truck and to extreme right covering up to four lanes from left lane)
7. Spread small amount of material to determine placement of material at various spinner and auger speeds in this far right position.
8. Various spread patterns may be acquired by placing spinner at various positions from left to right, and changing auger and spinner speeds on valve.

## Spreader Features:

1. Any valve setting changes may be made while truck is in motion.
2. Spinner and auger may be stopped at the same time, without changing their valve settings, by moving on-off lever to “off” position.



3. If auger clogs, it may be “shocked” loose by shutting off spinner, completely opening auger knob on valve, increasing engine speed and then rapidly moving valve lever to “on” and “off” positions. If this is not effective, manually unclogging machine is necessary.



**CAUTION !** Before working in auger area, valve lever must be in “off” position, PTO must be disengaged and engine must be shut off. Bottom gate may then be opened for unclogging auger

**NOTE:**

DISCONNECT SPINNER PARALLEL LINKAGE **BEFORE** OPENING BOTTOM GATE.



**CAUTION !** WHEN SPREADER IS REMOVED OR NOT IN USE THE VALVE ON-OFF LEVER SHOULD BE IN THE OFF POSITION. IF LEFT IN ON POSITION A HEAT PROBLEM MAY OCCUR IF PUMP CONTINUES TO PUMP OIL TO THE HYDRAULIC VALVE. THIS COULD CAUSE A HOSE TO BURST SPRAYING HOT OIL OVER EVERYTHING.

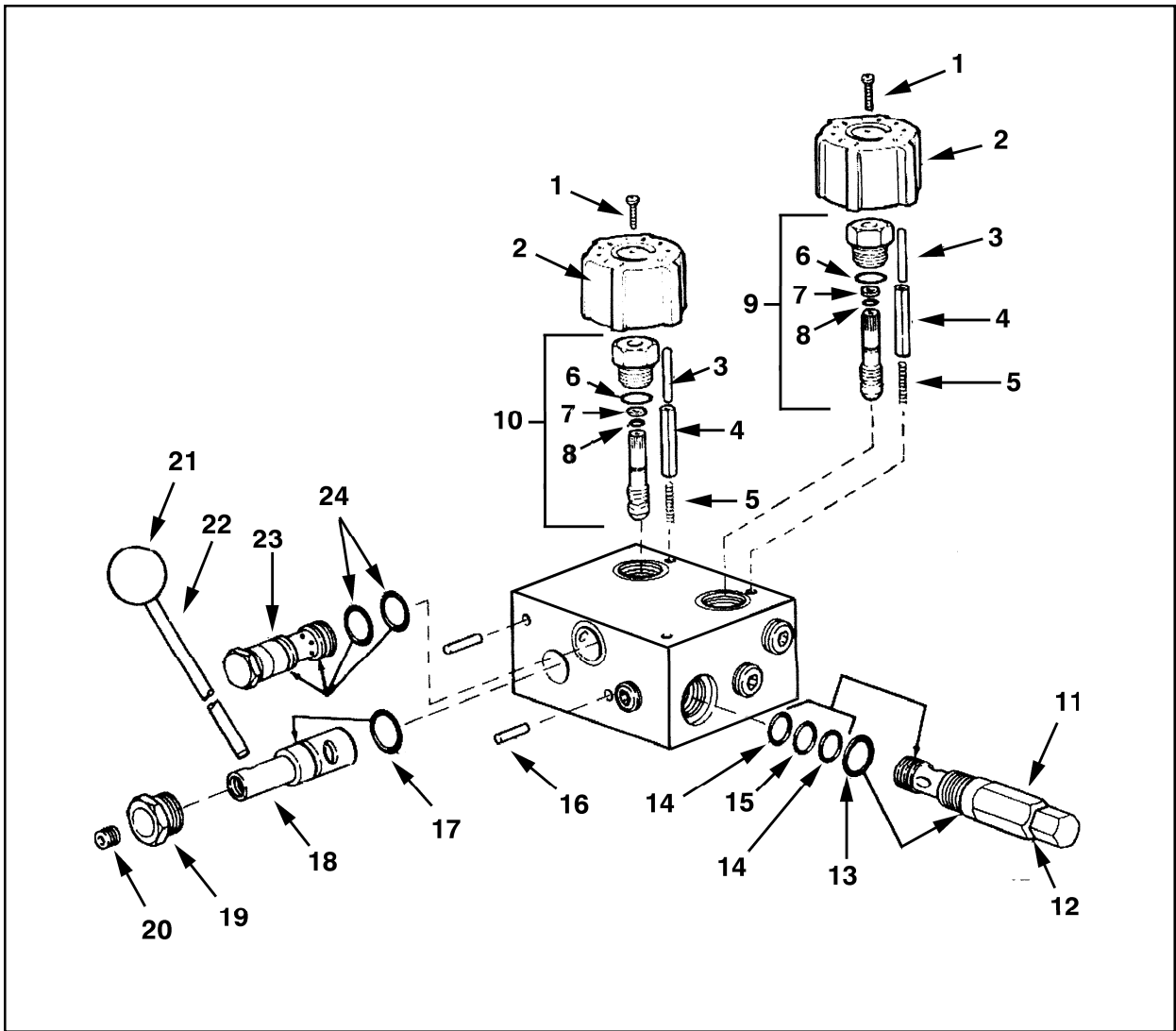

**DUAL FLOW CONTROL VALVE  
62213**

## DUAL HYDRAULIC FLOW CONTROL VALVE (62213)

### Parts List

Item	Part No.	Qty.	Description
1	62383	2	Screw
2	62098	2	Handknob
3	62384	2	Dowel Pin
4	62385	2	Roll Pin
5	62386	2	Spring
6	04105-285-06	2	O-Ring, Viton
7	04105-285-07	2	Back-up, Teflon ®
8	04105-285-08	2	O-Ring, Viton ®
-	62099		Kit, Seal - Consists of Items 6, 7, & 8
9	04105-285-10	1	Auger Adj. Assy. - 7 GPM
	04105-285-11	1	Auger Adj. Assy. - 10 GPM
	62387	1	Auger Adj. Assy. - 15 GPM
	04105-285-13	1	Auger Adj. Assy. - 20 GPM
	04105-285-14	1	Auger Adj. Assy. - 25 GPM
	04105-285-15	1	Auger Adj. Assy. - 30 GPM
10	04105-285-16	1	Spinner Adj. Assy. - 5 GPM
	62388	1	Spinner Adj. Assy. - 7 GPM
	04105-285-18	1	Spinner Adj. Assy. - 10 GPM
11	62389	1	Relief Cartridge
12	04105-285-20	1	Gasket
13	62100	1	O-Ring, Viton ®
14	04105-032-30	2	Back-up, Teflon ®
15	62102	1	O-Ring, Viton ®
16	04105-285-24	2	Roll Pin
17	62103	1	O-Ring (Dump Stem)- <b>(Not Available)</b>
18	04105-032-21	1	Stem <b>(NOT AVAILABLE)</b>
19	04105-285-26	1	Plug
20	62390	1	Setscrew
21	62391	1	Handknob
22	62392	1.	Lever
23	62393	1	Bypass Assy.
24	62104	2	O-Ring, Viton ®
	04105 285 40		NOT SHOWN Kit, Seal (For Item 11) Consists of Item 12, 13, 14 & 15
	62394		Kit, Seal Consists of Items: 6, 7, 8, 12, 13, 14, 15, 17, 23, 24

## RECOMMENDED MAINTENANCE FOR MATERIAL SPREADERS



### Caution !

1. Always replace shields and covers when maintenance is complete.

### Maintenance For All Material Spreaders:

1. Allow hydraulic system to warm up before using.
2. Maintain a three-fourths full reservoir using high grade nonfoaming hydraulic oil.
3. Avoid getting contaminants in reservoir when filling.
4. Replace filter cartridge (62382) with new cartridge at least twice a year and more often if necessary. (Optional gauge has red zone indicating when cartridge needs changing.
5. Clean quick disconnects before taking apart or connecting.
6. Protect quick disconnects while in use and after taking apart with suitable protection.
7. All bearings require periodic greasing, and more frequent greasing during periods of greater use.
8. Greasing pump shaft U-joints and slip-end of slip U-Joints is recommended with each truck lubricating.
9. Drive chains should be checked frequently, cleaned, greased, and taken up if slack is excessive.
10. Oiling or greasing spinner hinge rod (if on spreader) is suggested.
11. Gear boxes should be checked for proper lubrication level, and SAE 90 gear type lubricant added if necessary.
12. Drive chains and drag chains of all types should be checked for slack shortly after initial start up, and if necessary, slack should be taken up.
13. Hosing down and cleaning spreader after each use, and repainting or oiling after each season will greatly prolong spreader life.
14. Spreader trough or hopper should be kept empty to prevent material from freezing around conveyor in severe cold weather.

## HYDRAULIC TROUBLE-SHOOTING CHART

<p><b>CONDITION 1</b> Pump cavitation recognized by excessive noise.</p> <p><b>CAUSE</b></p> <ol style="list-style-type: none"> <li>Air entering system through suction lines.</li> <li>Suction line kinked, twisted or too long.</li> <li>Inadequate size suction line.</li> <li>Oil too heavy.</li> <li>Excessive pump speed. Normal pump speed 1200 to 1500 RPM.</li> </ol> <p><b>CORRECTION</b></p> <ol style="list-style-type: none"> <li>Check line from reservoir for possible leaks.</li> <li>Install suction line as short and straight as possible.</li> <li>Increase suction line size.</li> <li>Drain and replace with a low viscosity non detergent oil.</li> <li>Pump capacity is 16 GPM at 1000 RPM. Decrease PTO speed accordingly.</li> </ol>	<p><b>CONDITION 3</b> Erratic operation of auger and/or spinner.</p> <p><b>CAUSE</b></p> <ol style="list-style-type: none"> <li>Low oil.</li> <li>Worn or defective motor.</li> <li>Dirty, worn or defective flow control valve.</li> <li>Plugged filter.</li> <li>Relief valve setting too low.</li> <li>Pump cavitation.</li> <li>Air vent on reservoir tank is blocked.</li> </ol> <p><b>CORRECTION</b></p> <ol style="list-style-type: none"> <li>Fill reservoir to a 3/4 full level.</li> <li>Repair or replace motor.</li> <li>Clean repair or replace flow control.</li> <li>Replace filter element and clean filter.</li> <li>Adjust relief valve for 1500 PSI.</li> <li>Refer to pump section.</li> <li>Clean or replace vent cap to admit atmospheric pressure to inside the tank.</li> </ol>
<p><b>CONDITION 2</b> Slow operation of auger and/or spinner.</p> <p><b>CAUSE</b></p> <ol style="list-style-type: none"> <li>Worn or defective pump.</li> <li>Worn or defective motor.</li> <li>Pump cavitation.</li> <li>Insufficient pump speed.</li> </ol> <p><b>CORRECTION</b></p> <ol style="list-style-type: none"> <li>Repair or replace pump.</li> <li>Repair or replace motor.</li> <li>Refer to pump section.</li> <li>Pump capacity is 16 GPM at 1000 RPM. Increase PTO accordingly.</li> </ol>	<p><b>CONDITION 4</b> Auger and/or spinner will not operate.</p> <p><b>CAUSE</b></p> <ol style="list-style-type: none"> <li>Quick disconnects are dirty, damaged or improperly connected.</li> <li>Hose connections wrong.</li> <li>Foreign material in valve compensator</li> </ol> <p><b>CORRECTION</b></p> <ol style="list-style-type: none"> <li>Clean or replace and properly connect.</li> <li>Refer to illustration.</li> <li>Remove compensator and clean</li> </ol>

Meyer Products warranty does not cover unauthorized disassembly of Hydraulic or Electric components.

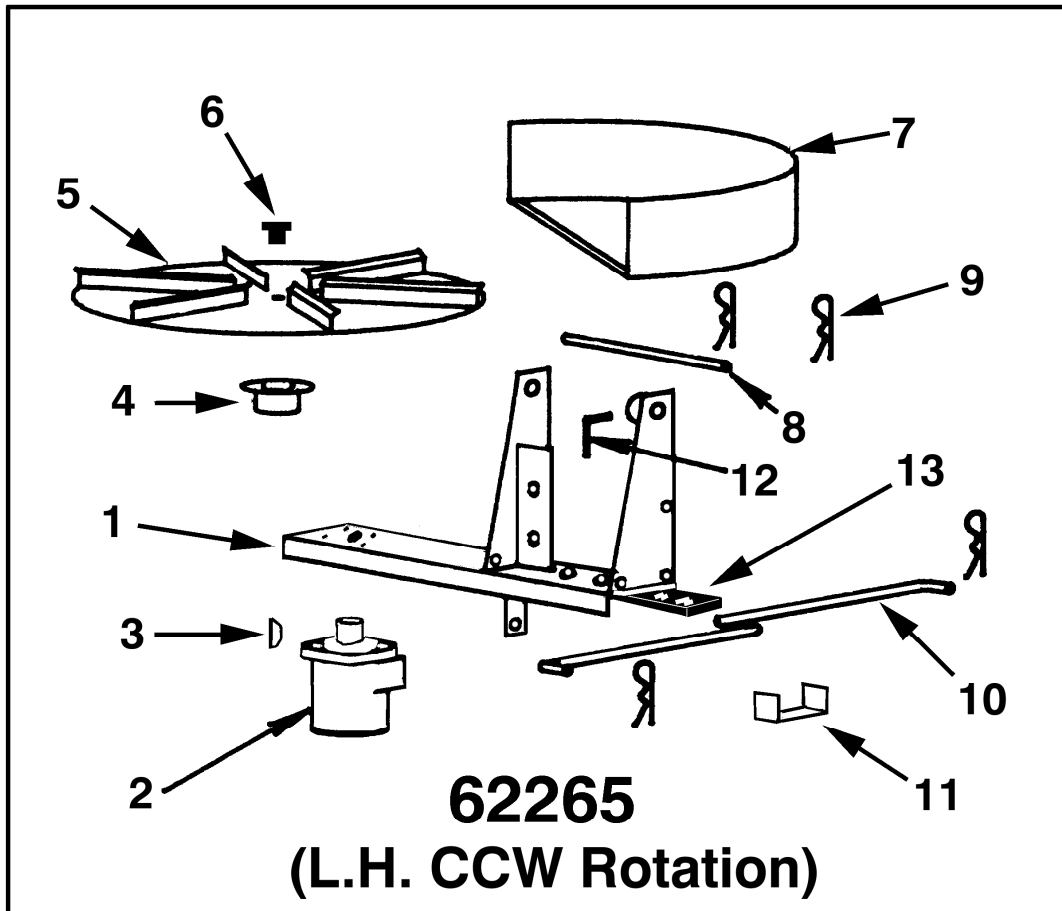

**SPINNER KIT (L.H. CCW ROTATION)**

**62265**

**(Includes Spreader Mounting Hardware)**

**(FOR SPINNERS LOCATED ON LEFT END OF TROUGH)**

Item	Part No.	Qty.	Description
1	62484	1	Weldment, Spinner Frame
2	60324	1	Motor, Hydraulic
3	21203	1	Key, 1/4" x 1" Woodruff
4	62454	1	Hub, Spinner
5	62455	1	Disc, Spinner (Polyurethane)
6	04003-001-16	1	Bolt, 1/4" x 1" H.H. S.S.
7	62456	1	Weldment, Spinner Shield
8	62457	1	Rod, Hinge
9	61233	4	Keeper, Hairpin
10	62415	2	Rod, Parallel Linkage
11	62458	1	Clamp, Hose
12	62459	1	Lock, Spinner

**ONE YEAR WARRANTY**

Meyer Products promises to the consumer to repair or, at Meyer Products' option, to replace any part of this Meyer Spreader except expendable parts such as pins, spreader fins, and other normal wear items, which proves to be defective in workmanship or material under normal use for a period of one year from the date of delivery to the original purchaser. During this one year, Meyer Products will provide, to the consumer, through its Distributor / Sub-Distributor network, all parts necessary to correct such defects free of charge. Labor costs incurred for any repairs on this piece of equipment will be the responsibility of the consumer. Faulty parts will be repaired or replaced by the Distributor / Sub-Distributor where that particular piece of equipment was purchased. Any cost incurred in returning the product to the Distributor / Sub-Distributor is the responsibility of the consumer.

The gasoline engine used in this product is covered by its own warranty as provided by the engine manufacturer. A copy of this warranty is included with the engine.

**EXCLUSIONS**

IN NO EVENT SHALL MEYER PRODUCTS BE LIABLE FOR SPECIAL, INCIDENTAL OR CONSEQUENTIAL DAMAGES OR FOR DAMAGES RESULTING FROM LACK OF NECESSARY MAINTENANCE, FROM MISUSE, ABUSE, ACTS OF GOD, ALTERATION OF THE MEYER PRODUCT, OR FROM USE OF PARTS OR HYDRAULIC FLUID NOT SUPPLIED BY MEYER PRODUCTS. USE OF THE MEYER SNOWPLOW FOR ANY PURPOSE OTHER THAN PLOW-

ING SNOW IS ONE EXAMPLE OF AN ABUSE AND MISUSE OF THE PRODUCT.

**WARRANTY SERVICE**

In order to obtain service under this warranty, the consumer must return this Meyer product to the Distributor / Sub-Distributor from whom the product was purchased or to any other Meyer Products Distributor / Sub-Distributor, transportation and freight charges prepaid. Only Meyer Products Distributor / Sub-Distributors are authorized to perform the obligations under these warranties. For the address and telephone number of the Distributor / Sub-Distributor nearest you, check the telephone directory or you may write to the warrantor at the address below.

**GENERAL**

It is the responsibility of the consumer to establish the warranty period by verifying the original delivery date. A bill of sale, cancelled check or some other appropriate payment record may be kept for that purpose. It is recommended, but not required, that the consumer verify the original delivery date by immediately returning the attached Warranty Registration Card. No person is authorized to change this warranty or to create any warranty other than that set forth herein. This warranty gives you specific legal rights and you may also have other rights which vary from state to state.

Meyer Products  
18513 Euclid Avenue  
Cleveland, Ohio 44112  
Phone (216) 486-1313  
Fax (216) 486-3073  
E-Mail info@meyerproducts.com

In order to validate this warranty, please complete this card and mail it.

Name: \_\_\_\_\_

Address: \_\_\_\_\_  
\_\_\_\_\_

Spreader Model: \_\_\_\_\_ Serial No.: \_\_\_\_\_

Installation Date: \_\_\_\_\_ Purchased From: \_\_\_\_\_

## NAME PLATE INFORMATION

- When ordering parts or requesting information or assistance, always include the information listed below.
- The Model Number and Serial Number for the Spreader are shown on the Name Plate.
- The space below is provided as a convenient place to record these numbers; just fill in the blanks.

Model No. \_\_\_\_\_

Serial No. \_\_\_\_\_

Date Purchased \_\_\_\_\_

Purchased From \_\_\_\_\_

Phone No. For Service \_\_\_\_\_

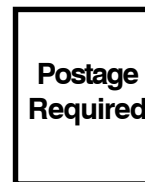

**Meyer Products**  
**18513 Euclid Avenue**  
**Cleveland, Ohio 44112-1084**

nts: