



Operation and Maintenance Manual

For use with Standard &
Deluxe Crossfire Spreaders



Registration Data Sheet

Register your spreader at www.meyerproducts.com

Owner Name _____

Address _____

City _____

State/Province _____ Zip/Postal Code _____

Purchased From Company Name _____

Contact Name _____

Address _____

City _____

State/Province _____ Zip/Postal Code _____

Phone Number (_____) _____

E-mail _____

Date Purchased _____

Vehicle Make _____ Vehicle Model _____

Vehicle Year _____ Spreader Model _____

Spreader Serial Number _____



Thank You...

Thank you for buying your Meyer Spreader. As a new owner of hard-working, mechanical equipment, we strongly urge you to spend quality time with this owner's manual. It's easy to use and full of time-saving tips that will enhance your ownership experience. It includes suggestions for faster installation, safe operation and more productive spreading.

We also strongly urge you to register your new Meyer spreader at meyerproducts.com. Registering will only take minutes and the benefits of doing so will last for years. When registered, you will receive timely and accurate communication on operation tips, maintenance, new products, and service bulletins. And in the unlikely event you need warranty work performed, your local servicing dealer will be able to process your claim faster.

*Thanks again for your business. You can now look forward to many years of reliable performance and keeping your driveway safer and easier to use. If you have any questions about your Meyer spreader, contact us at: **www.meyerproducts.com** or call **216-486-1313**.*



Andy Outcalt, President, Meyer Products, LLC.

Table of Contents



Registration Data Sheet	1
Thank You	2
Introduction	4
EC Declaration of Conformity	4
Safety Definitions & Warnings	5-7
Safety Decal Locations	8-11
Safety Guards	12-15
Spreader Component Identification.....	23-24
Vehicle Loading	32-33
Installation / Assembly Instructions	34-47
Controller Operation	48-55
Electrical Schematics.....	56-60
Maintenance.....	61-64
Troubleshooting.....	65-71
Warranty/Contact Meyer.....	72

Introduction

Snow and ice, despite the beauty it may impart to a bleak winter landscape, poses the dual threat of inconvenience and danger. The environmental conditions associated with snow and ice, not to mention the health hazards and economic loss it may impose, seriously endanger thousands of lives annually. Business and industry suffer, and millions of snowbelt residents may be affected by a single snowstorm.

Meyer Products LLC has published this manual to help you get the maximum performance from your Meyer spreader and familiarize you with the features designed for efficiency and safety; be sure you recognize and understand them. Follow recommended operation and maintenance instructions, so when the storm hits, your Meyer spreader will be ready and you will know how to spread like a pro.

DO NOT EQUIP ANY VEHICLE WITH A SPREADER WITHOUT CONSULTING VEHICLE MANUFACTURERS' RECOMMENDATIONS.

Vehicles equipped with Meyer spreaders installed may be so equipped as to meet vehicle manufacturers' specifications and recommended options for material spreading use. **Most vehicle manufacturers insist that vehicles which are to be used for ice control be equipped with certain options and accessories, and it is so stated in vehicle manufacturer specifications for snow plow application.**

WARNING: Deployment of an air bag while using a Meyer Spreader will not be covered under Meyer Products' warranty. We also recommend that, for optimum performance, vehicles used for ice control be equipped with:

- Four-Wheel Drive
- Minimum 60 Amp Alternator or larger
- Minimum 70 Amp Battery or larger (550 C.C.A.)
- Mud and Snow Tires
- Increased Radiator Cooling
- Automatic Transmission
- Power Brakes
- Power Steering

Under the continuing Meyer Product Improvement Plan, Meyer Products LLC reserves the right to change design details and construction without prior notice and without incurring any obligation.

EC Declaration of Conformity

EC DECLARATION OF CONFORMITY

The undersigned representing the manufacturer _____ and the authorized representative established within the community _____

I hereby declare that the Product: **Snow & Ice Equipment**

Model/Type ref.: **Jason Meyer Salt Spreader LPT10V**

It is conformity with the Essential requirements of the following EC Directives when subject to correct installation, maintenance and use conforming to their intended purpose, to the applicable regulations and standards, to our operation and maintenance manual.

2006/55/EC	EC Low Voltage Directive
2004/108/EC	EMC Directive
2006/42/EC	Machinery Directive

and that the Standards and/or technical specifications referenced below have been applied:

1. BS EN 60204-1:2006 / IEC 60204-1:2005. Safety of machinery - Electrical equipment of machines-Part 1: General requirements.
1. EN ISO 12100-1:2003-Safety of Machinery - Basic Concepts, General Principles of Design Part 1: Basic Terminology and Methodology
1. EN ISO 12100-2:2003-Safety of Machinery - Basic Concepts, General Principles of Design Part 2: Technical principles
1. EN 13021:2003-HA1- Water service machines - Safety requirements
1. EN 61000-6-2: 2005. Generic standards - Immunity for Industrial Environments.
1. EN 61000-6-4:2005. Generic emission standard, Part 2: Industrial environment.

Type of CE Marking: 2011

Manufacturer: _____ Authorized Representative in the community: _____

Signature: *[Signature]* Position: *[Signature]*

Date: *12-11-2011* Date: *12-11-2011*

Place: *London, Ontario, Canada* Place: *London, Ontario, Canada*

OFFICIAL SEAL
CONFERENCE DES EPICERIES
PROVINCE QUÉBEC
By Commission Services (art. 55, 56)

Safety Definitions

These safety alert decals are used to alert you of potential personal injury hazards. Obey all safety messages that follow this symbol to avoid possible injury or death.



DANGER Conveyor

This decal alerts all to the danger of serious personal injury or death while servicing or cleaning this equipment without first turning off or disconnecting all power sources.



CAUTION

This decal cautions all to observe general safety procedures when operating, moving, storing, cleaning or servicing this equipment.



DANGER Spinner

This decal alerts all to the danger of any person being near the spinner while it is turning where serious personal injury could result if struck by flying debris.

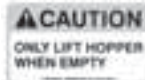

CAUTION Empty Hopper

This decal cautions all to only lift or move equipment when hopper is empty to prevent the risk of serious personal injury or property damage.



CAUTION

This decal cautions all to the risk of the tank containing hazardous chemicals. Operators should wear appropriate PPE when contact with chemicals is possible.



CAUTION Fork Length

This decal cautions all to make sure fork lift arms extend a minimum of 4"(10.2cm) past both brackets before lifting or moving equipment to prevent the risk of serious personal injury or property damage.



Safety Definitions & Warnings

SAFETY DEFINITIONS



This is the safety alert symbol. It is used to alert you to potential personal injury hazards. Obey all safety messages that follow this symbol to avoid possible injury or death.

DANGER

DANGER Indicates an imminently hazardous situation which, if not avoided, will result in death or serious injury.

WARNING

WARNING Indicates a potentially hazardous situation which, if not avoided, could result in death or serious injury.

CAUTION

CAUTION Indicates a potentially hazardous situation which, if not avoided, may result in minor or moderate injury.

CAUTION

CAUTION used without the safety alert symbol indicates a potentially hazardous situation which, if not avoided, will result in property damage.

1	DANGER	NEVER stand or ride on the spreader. Failure to comply will result in death or serious injury.
2	DANGER	Keep hands, feet, and clothing away from power driven parts. Failure to comply will result in death or serious injury.
3	DANGER	Make sure spreader is completely shut off and all movement has stopped before attempting to clean, service or unclog. Failure to comply will result in death or serious injury.
4	DANGER	NEVER enter hopper while spreader is operating or capable of being operated. Failure to comply will result in death or serious injury.
5	WARNING	NEVER operate or service your spreader without first CAREFULLY reading the Owner's Manual. It is CRITICAL for your safety to ALWAYS obey EVERY warning in the manual and follow EVERY instruction EXPLICITLY. Failure to comply could result in death or serious injury.
6	WARNING	Never leave operator's position without first completely turning off spreader, disengaging PTO, shutting off hydraulic valve and setting vehicle parking brake. Failure to comply will result in death or serious injury.
7	WARNING	Never operate spreader without all shields, guards, and safety decals in place. Failure to comply will result in death or serious injury.
8	WARNING	Spreader should only be operated by personnel trained in the safe use and transportation of this equipment.
9	WARNING	The spreader should NEVER be used for any other purpose other than spreading ice melting or traction products on streets, parking lots and driveways. Failure to comply will result in property damage, death or serious injury.
10	WARNING	Inspect spreader assembly and mounting components and fasteners for wear and damage before and after each use. Worn or damaged components or fasteners could allow spreader to break free from the transport vehicle. Failure to comply will result in death or serious injury.
11	WARNING	Transport vehicle must not be operated when overloaded. In all cases, the loaded vehicle weight, including the entire spreader system, all aftermarket accessories, driver, passenger, options, nominal fluid levels, and cargo must not exceed the front/rear Gross Axle Weight Rating (GAWR), and total Gross Vehicle Weight Rating (GVWR). These weights ratings are specified on the safety compliance certification label on the driver's side door opening. Failure to comply will result in death or serious injury.
12	WARNING	Spreader may tip over or fall. Spreader should be solidly supported when being mounted, dismantled, moved, or stored. Failure to comply will result in death or serious injury.
13	WARNING	Operator, bystanders and pets should be kept at least 50 feet away from spreader during operation. Failure to comply will result in death or serious injury.
14	WARNING	SAFETY PRECAUTIONS should be used when hydraulic system is operating or being serviced. Hydraulic fluid under pressure can cause a skin injection injury. If you are injured by hydraulic fluid, get medical attention immediately. Failure to comply will result in death or serious injury.
15	WARNING	Engine exhaust contains lethal fumes. Breathing these fumes, even in low concentrations, can cause death. Never operate engine in an enclosed area without venting the exhaust to the outside. Failure to comply will result in death or serious injury.

Safety Definitions & Warnings



16		Gasoline is highly flammable and gasoline vapor is explosive. Never smoke while working on vehicle or spreader. Keep all open flames away from gasoline tank and lines. Wipe up any spilled gasoline immediately. Failure to comply will result in death or serious injury.
17		NEVER operate the spreader gasoline engine without first CAREFULLY reading the Owner's Manual. It is CRITICAL for your safety to ALWAYS obey EVERY warning in the manual and follow EVERY instruction EXPLICITLY. Failure to comply will result in death or serious injury.
18		A driver's first responsibility is the safe operation of the vehicle and spreader. The most important thing you can do to prevent a crash is to avoid distractions and pay attention to the road. Wait until it is safe to operate mobile communication equipment such as cell phones, two way radios, etc. Failure to comply will result in injury.
19		Vehicle must conform to all local, state, and national regulations regarding the use of reflective markings and flashing lights. Failure to comply will result in injury.
20		Batteries normally produce explosive gases which can cause personnel injury. Therefore, do not allow flames, sparks or lit tobacco to come near the battery. When charging or working near a battery, always cover your face and protect your eyes, and also provide ventilation. Batteries contain sulfuric acid which burns skin, eyes, and clothing. Failure to comply will result in injury.
21		Never transport spreader with spinner in the raised position. Failure to comply will result in property damage.
22		Installation of a Meyer spreader may affect your new vehicle warranty. Before beginning spreader installation verify mounting method is acceptable to your vehicle manufacturer. Failure to comply will result in property damage.
23		Warranty does not apply to a Meyer spreader product which has been negligently or improperly assembled or installed. Failure to comply will result in property damage.
24		CAUTION: To avoid harm to vehicles electrical system always disconnect battery before beginning installation. DO NOT BURN holes or WELD vehicle frame. This may cause frame failure. Failure to comply will result in property damage.
25		CAUTION: To avoid harm to spreader electrical system always disconnect battery before beginning installation or service. Do not operate spreader with a missing, discharged or dead battery. Failure to comply will result in property damage.
26		The Meyer spreader electrical system contains several automotive style fuses. If a problem should occur and fuse replacement is necessary, the replacement fuse must be of the same type and amperage as the original. Installing a fuse with a higher rating can damage the system and could cause a fire. Failure to comply will result in property damage.
27		Spreader is not designed to be chassis mounted. Do not support spreader by body jacks alone. Spreader must be installed directly onto truck bed. Failure to comply will result in property damage.

SAFETY DEFINITIONS



This is the safety alert symbol. It is used to alert you to potential personal injury hazards. Obey all safety messages that follow this symbol to avoid possible injury or death.



DANGER Indicates an imminently hazardous situation which, if not avoided, will result in death or serious injury.



WARNING Indicates a potentially hazardous situation which, if not avoided, could result in death or serious injury.



CAUTION Indicates a potentially hazardous situation which, if not avoided, may result in minor or moderate injury.



CAUTION used without the safety alert symbol indicates a potentially hazardous situation which, if not avoided, will result in property damage.

Safety Decal Locations

These safety alert decals are used to alert you of potential personal injury hazards. Obey all safety messages that follow the symbol to avoid possible injury or death.



Safety Decal Locations

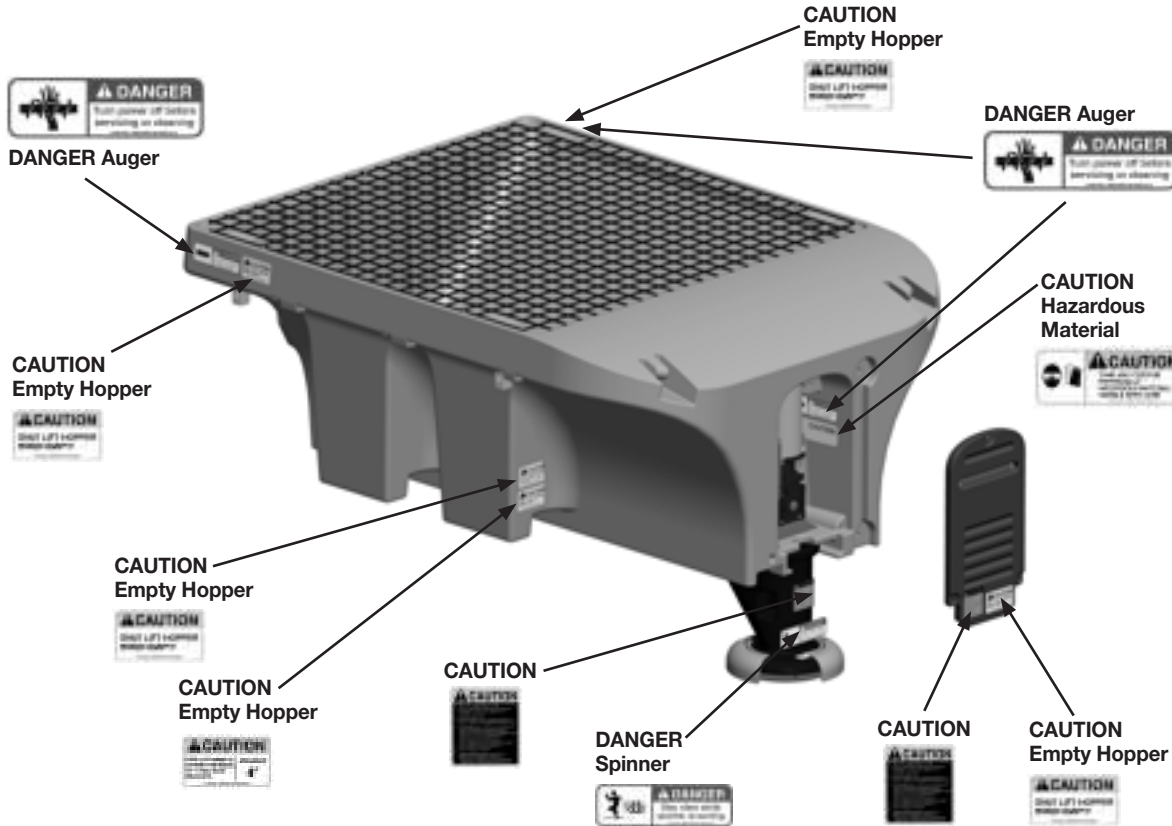

DANGER Conveyor decal alerts all to the danger of serious personal injury or death while servicing or cleaning this equipment without first turning off or disconnecting all power sources.

DANGER Spinner decal alerts all to the danger of any person being near the spinner while it is turning where serious personal injury could result if struck by flying debris.

CAUTION decal cautions all to observe general safety procedures when operating, moving, storing, cleaning or servicing this equipment.

CAUTION Empty Hopper decal cautions all to only lift or move equipment when hopper is empty to prevent the risk of serious personal injury or property damage.

CAUTION Fork Length decal cautions all to make sure fork lift arms extend a minimum of 4" past both brackets before lifting or moving equipment to prevent the risk of serious personal injury or property damage.

CAUTION Hazardous Material decal cautions all to the possibility the tank may contain hazardous material. Proper PPE should be worn at all times while working with hazardous chemicals.

Safety Guards

To prevent serious personal injury or death all safety guards/covers must be securely fastened in the proper location while equipment is operating or capable of being operated.



Safety Guards

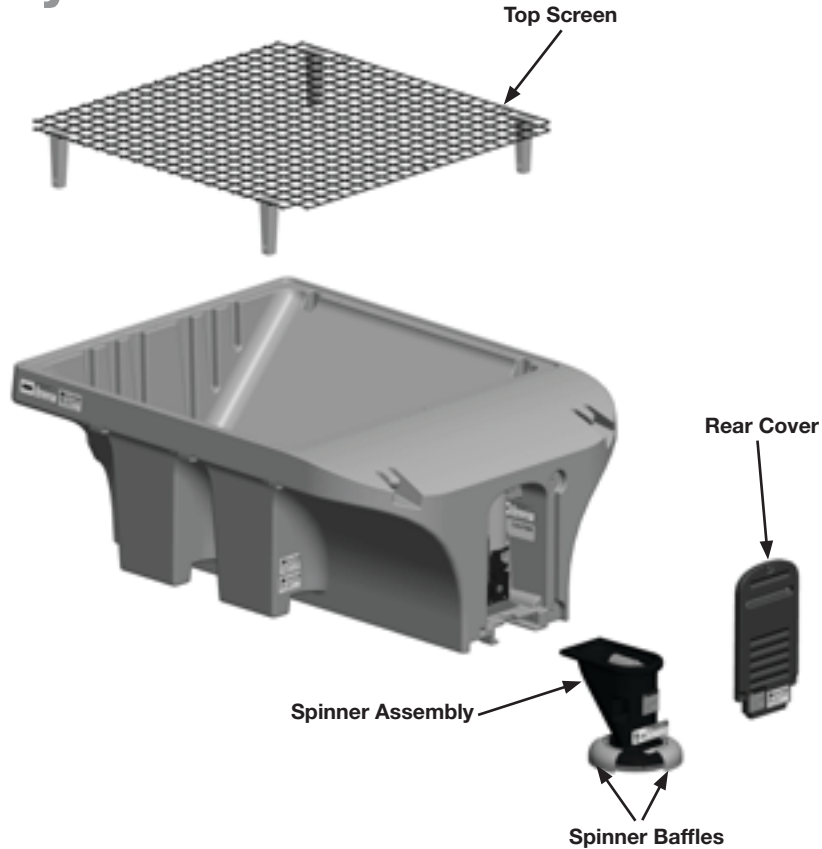

Component Identification

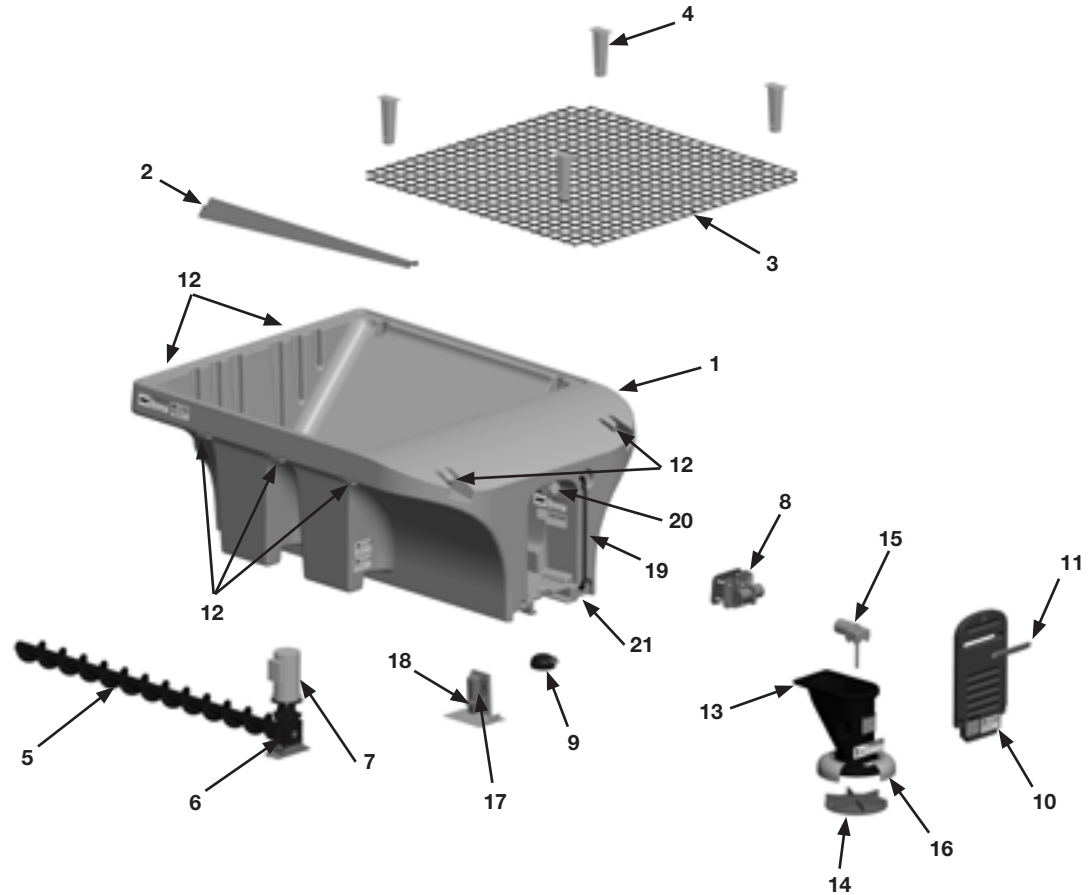

Component Identification



- 1. Hopper** – Molded poly hopper holds spreading material and pre-wet liquid.
- 2. Inverted Vee** – Relieves weight of material on the auger.
- 3. Top Screen** – Breaks up large clumps of material and prevents foreign objects from entering hopper.
- 4. Screen Stakes** – Secures screen to the hopper and is also the attachment point for the hold down straps or chains.
- 5. Auger** – Is driven by the gearbox and moves material out of hopper to the spinner assembly.
- 6. Gearbox** – Receives power from the electric motor and rotates the auger.
- 7. Electric Motor**– Supplies power to the gearbox to drive the auger.
- 8. Vibrator** – Breaks up material clumps and allows material to free flow to the auger.
- 9. Work Light** – Allows operator to see material being spread while operating at night.
- 10. Rear Cover** – Covers control system and drive parts to keep out moisture and prevents access to moving auger.
- 11. CHMSL** – Complies with Federal Motor Vehicle Safety Standards.
- 12. Tarp Hooks** - Provides location to attach tarp to hopper.
- 13. Spinner Assembly** – Attaches to the rear of the spreader and distributes the spreading material onto road the surface.
- 14. Spinner Disc** – Rotates at a high RPM and throws material out of the spinner assembly.
- 15. Spinner Motor** – Supplies power to drive the spinner disc.
- 16. External Baffles** – Adjusts the width of the spread pattern behind the vehicle.
- 17. Pre-wet Pump** - pumps liquid to spray nozzle located on the spinner assembly.
- 18. Liquid Strainer** - filters solids and debris from pre-wet liquid to prevent clogging spray nozzle.
- 19. Sight Gauge** - Allows operator to visually check level of pre-wet liquid inside hopper.
- 20. Fill Port** - Allows hopper to be filled with pre-wet liquid.
- 21. Liquid Drain** - Allows pre-wet liquid to be drained from hopper.

Vehicle Loading

Determining Vehicle Payload

It is necessary to calculate the available material payload to prevent overloading the vehicle. Overloading the vehicle can create dangerous stability and braking problems. Always consult and follow vehicle manufacturer's weight ratings and mounting instructions.

1. Mount complete spreader and any optional equipment on vehicle.
2. Attach all additional equipment onto vehicle such as snow plow, hitch, etc that will be used when spreader is mounted on vehicle.
3. Fill fuel tanks.
4. With normal operator(s) inside of vehicle, weigh vehicle to obtain the Gross Vehicle Weight (GVW).
5. Obtain Gross Vehicle Weight Rating (GVWR), Front Gross Axle Weight Rating (FGAWR), and Rear Gross Axle Weight Rating (RGAWR) from the driver's door jam or from the vehicle manufacturer.

6. Subtract the GVW from the GVWR to obtain the available material payload.
7. Divide the payload by the material density (see Material Density Chart) to determine the maximum volume of material that can be carried by the vehicle.
8. Refer to Spreader Capacity Chart to determine the recommended level to fill hopper to obtain desired payload.
9. Load spreader with material to the calculated height.
10. Weigh vehicle to verify vehicle does not exceed GVWR, FGAWR, or RGAWR.
11. Repeat procedure for each type of spreading material to be used.

Note: Material weights shown in Material Density Chart are average material weights. Actual weight of materials may vary depending on vendor and the geographic area the materials are obtained from.



Material Capacity

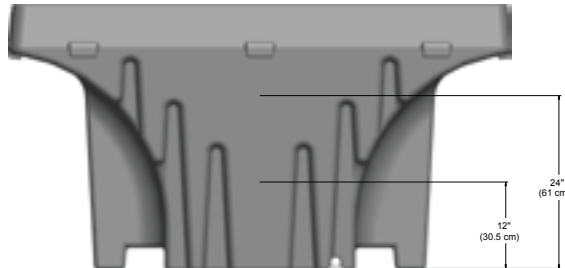

Liquid Capacity



Vehicle Loading



Spreader Capacity

Granular Volume at Specified Height (Cu. Yds.)

Spreader	Full	24"	12"
6'	1.50	0.61	0.11
8'	2.00	0.84	0.15

Liquid Volume at Specified Height (Gallons)

Spreader	Full	19"	9"
6'	175	149	80
8'	225	196	107

Granular Volume at Specified Height (M3)

Spreader	Full	24"	12"
6'	1.15	0.47	0.08
8'	1.53	0.64	0.11

Liquid Volume at Specified Height (Liters)

Spreader	Full	19"	9"
6'	663	564	303
8'	852	742	405

Side Extension Granular Capacity

Spreader	Cu. Yds.	M3
6'	0.59	0.45
8'	0.83	0.63

Material Density

Granular	Density	
	lbs. per cubic yard	kg per M3
Coarse Salt - Dry	2,052	932
Coarse Sand - Dry	2,700	1,227
Coarse Sand - Wet	3,240	1,472
Liquid	Density	
	lbs. per gallon	kg per liter
Sodium Chloride	9.80	4.44
Magnesium Chloride	10.75	4.88
Calcium Chloride	10.85	4.92



Installation / Assembly Instructions

Center High Mount Stop Lamp Installation (CHMSL)

Federal Motor Vehicle Safety Standards require all trucks, buses, and multipurpose passenger vehicles manufactured on or after 5/1/1993, with a gross vehicle weight rating (GVWR) of 10,000 LBS. or less and an overall width less than 80" be equipped with a center high mount stop lamp (CHMSL). If the original vehicle CHMSL is obscured, an auxiliary CHMSL must be installed to bring the vehicle back into compliance with Federal Regulations. Spreader is furnished with an auxiliary CHMSL and wire harnesses for connection to vehicle electrical system. Consult vehicle manufacturer's recommendations for approved method of connecting CHMSL to vehicle. Refer to the Wire Schematic section in this manual for additional information.



Installation / Assembly Instructions



Spreader Mounting

1. Place spreader directly onto bed of vehicle with discharge at the rear of the vehicle.
2. Attach spinner assembly.
3. Reposition spreader on vehicle bed just short of spinner assembly making contact with the rear most part of the vehicle.
5. Install one ratchet strap from each corner of truck bed to appropriate Screen Stake.

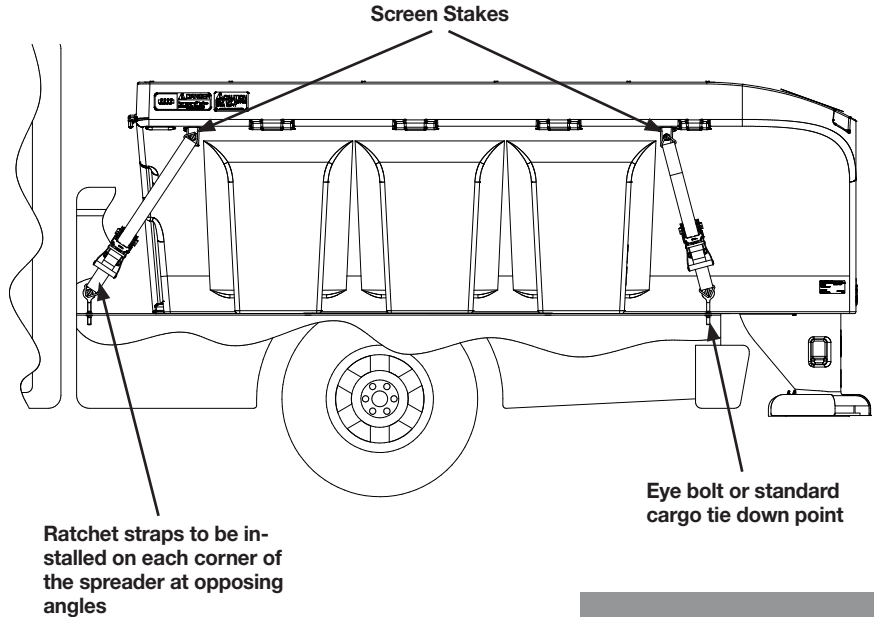

Installation / Assembly Instructions



**LIFTING & TIE DOWN
LOCATIONS**

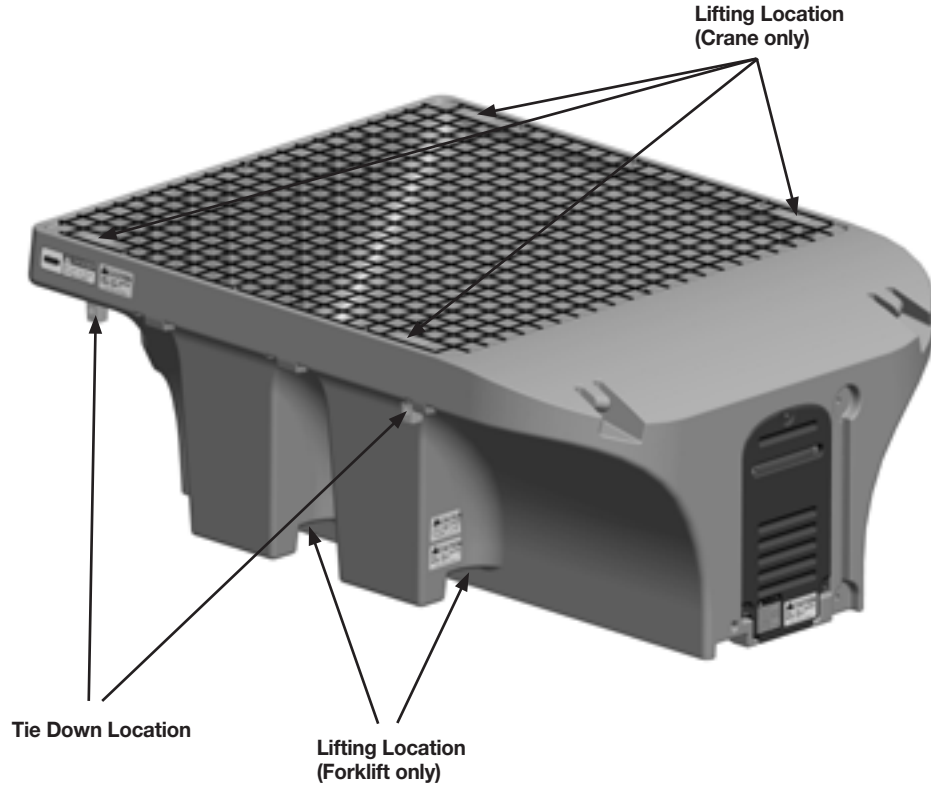

Installation / Assembly Instructions

The Crossfire spreader can be mounted and stored as a single unit. The Crossfire spreader will mount on most medium or heavy duty pickup trucks. The Crossfire spreader can be mounted on 1 ton or larger trucks, but may require optional extended spinner.

Vehicle Preparation

Overloading vehicle can create dangerous stability and braking problems. Always consult and follow vehicle manufacturers weight ratings and mounting instructions.

1. Turn off vehicle engine, set parking brake, and remove keys.
2. Remove tailgate from vehicle.
3. Remove trailer hitch if equipped.

Spreader Preparation

1. Remove all loose items from inside of hopper such as the spinner assembly, controller, etc.
2. Make sure hopper is completely empty before attempting to lift or move spreader.

Lifting Spreader

All chains, hooks, and straps must be of an adequate weight rating to support entire spreader including any additional or optional equipment that may be installed. Never attempt to lift or move a spreader with material in the hopper.

1. Forklift Pockets: The Crossfire spreader can be lifted with a forklift by utilizing the rear forklift pockets. Extended forks are recommended for use with the forklift pockets. Verify forklift is of an adequate weight rating to prevent forklift from tipping while moving spreader.
2. Spreader can be lifted by removing the screen stakes and attaching a lifting strap to through each screen stake pocket in a choker configuration.

Spreader Installation

The Crossfire spreader should be mounted directly on the vehicle bed, spreader is not designed to be supported by body jacks alone or for chassis mount applications. Shipping skid is intended to be removed before mounting spreader. Verify mounting method is acceptable to the vehicle manufacturer before attempting to mount spreader.

1. Place spreader directly onto bed of vehicle with discharge at the rear of the vehicle.
2. Spreader is designed sit directly on vehicle bed. Do not support spreader by body jacks alone. Spreader is not designed to be chassis mounted.
3. Attach spinner assembly to spreader. Make sure spreader cannot tip when spinner assembly is installed (see spinner assembly installation instructions).
4. Reposition spreader on vehicle bed, just short of the spinner assembly making contact with the rear most part of the bed, bumper, pintle hook, etc.
5. Adequate tie down locations are necessary for proper installation of the Crossfire spreader. Vehicle should be equipped with cargo tie down brackets in each corner of bed. If vehicle is not equipped cargo tie down brackets, a minimum of four 1/2" eye bolts or d-rings will need to be added to vehicle bed.
6. Install one ratchet strap from each corner of vehicle bed to appropriate spreader tie down location. Straps should be installed at opposing angles to prevent spreader from sliding in vehicle bed.



Installation / Assembly Instructions

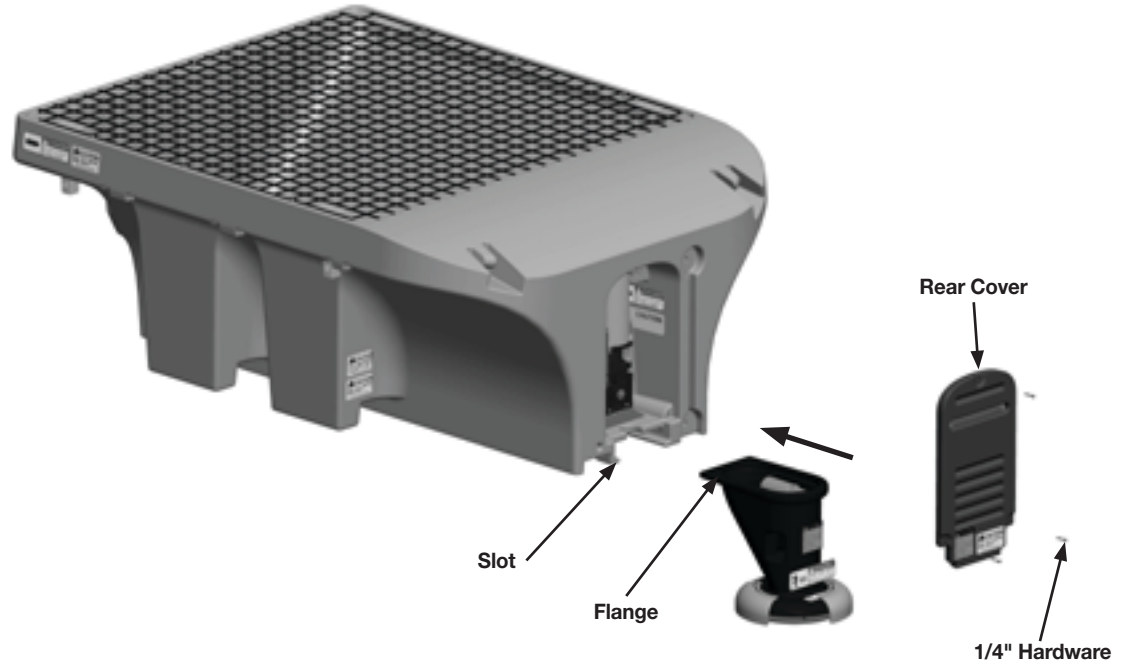
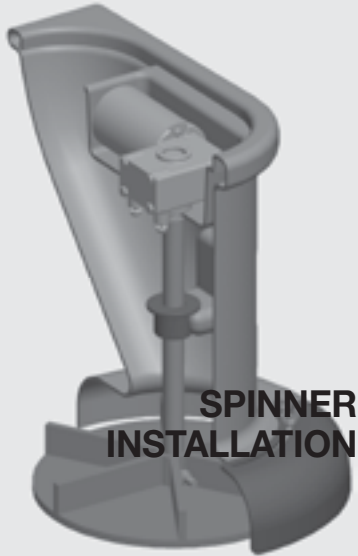

Installation / Assembly Instructions



Spinner Assembly Installation

Spinner should be solidly supported during installation. Spinner assembly weighs over 50 lbs. (22.7 kg) and may require more than one person for safe installation.

1. Remove three 1/4" bolts and remove rear cover from spreader. CHMSL will need to be disconnected to fully remove Rear Cover.
2. Align top flange of spinner assembly with the slots in the hopper. Slide spinner into hopper until fully engaged in slots.
3. Connect spinner harness to appropriate harness from control system.
4. Reconnect CHMSL, reinstall rear cover onto spreader and secure with 1/4" bolts.

Deluxe Spreader Controller

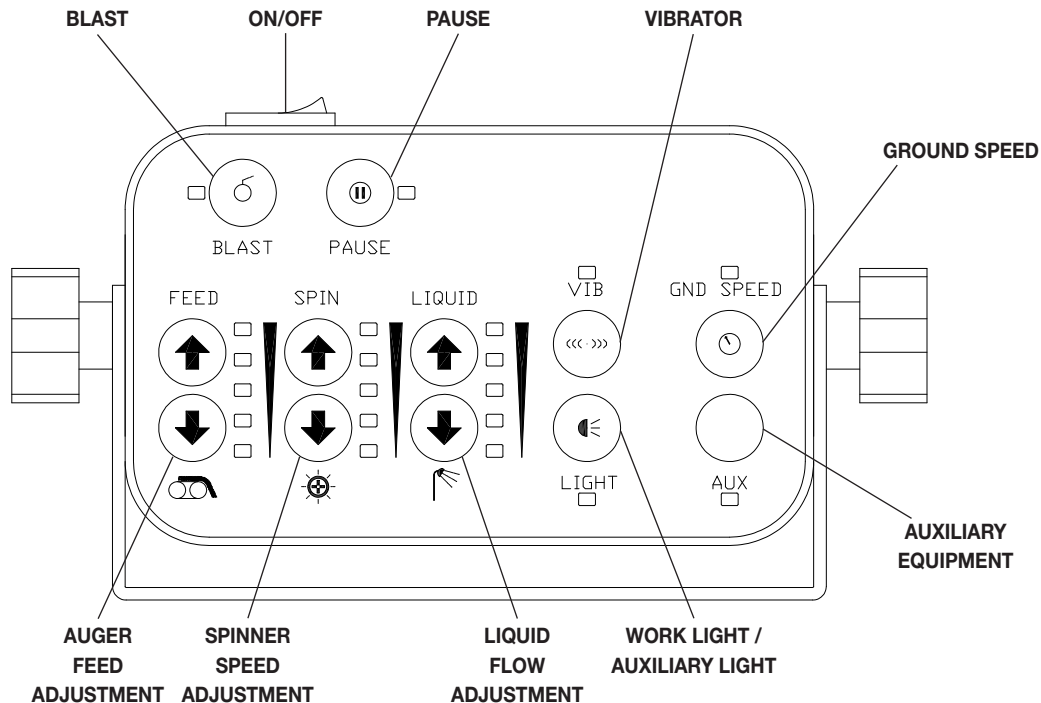

Deluxe Spreader Controller



The Deluxe Spreader Controller is intended to control the following functions of the spreader: auger feed rate, spinner speed, liquid flow rate, blast, pause, vibrate, and ground speed. The controller also includes circuits for auxiliary lighting and accessories. The control system is made up of the control panel, high current module (HCM), and wiring harnesses. The controller is intended to be permanently mounted inside the cab of the vehicle.

OVERVIEW The deluxe spreader control system offers independent output control for the auger rate, spinner rate, and pre-wet flow. The deluxe spreader control system can be configured in three ways during set up: a) manual operation only (no ground speed); b) ground speed triggered on/off; or c) ground speed oriented on/off. The deluxe spreader control system also allows for the auger feed and spinner speed rates to be "trimmed" during set up. An "ideally trimmed" system will allow the auger, spinner, and pre-wet circuits to begin to operate at setting 1 and reach their maximum speeds at setting 10.

OPERATION When the ON/OFF switch is in the "OFF" position, the controller has no functions and spreader will not operate. When ON/OFF switch is in the "ON" position, the spreader functions are able to be used and the spreader can be operated. When the controller is on red will be visible on the ON/OFF switch.

PAUSE FEATURE When the pause mode is activated the auger, spinner, and pre-wet functions will not operate and the red LED light next to the PAUSE button will illuminate. Pressing the PAUSE button will activate the pause mode, pressing the button a second time will deactivate the pause mode. To prevent accidental operation of the spreader, the pause mode is activated each time the controller is turned on and will not operate until the pause mode has been deactivated.

BLAST FEATURE When the blast feature is activated the red LED light next to the BLAST button will illuminate and the auger, spinner, and pre-wet functions will automatically operate at setting "10" regardless of where they were set before the blast mode was activated. Once the blast mode is deactivated the auger, spinner, and pre-wet functions will return to their previous settings. The blast mode can be configured at set up to operate as on/off or as a "timed blast".

VARIABLE SPEED SETTINGS The controller is equipped with three variable speed functions, one each for the auger feed rate, spinner speed rate, and pre-wet flow rate. Variable speed functions have settings of 0 -10 with setting 10 being full output. The variable speed settings can be changed by pressing the AUGER, SPINNER, or LIQUID "up" buttons to increase the output, and the "down" buttons to decrease the output. Each variable speed function has five red LED lights to provide a visual indication of the current setting. Variable speed settings will not operate at setting "0". Each time the controller is turned on the variable speed settings will automatically be at setting "0" to prevent accidental operation of the spreader. Any time the variable speed setting is at any setting higher than "0" the auger, spinner, or pre-wet function is capable of operating.

Deluxe Spreader Controller

VIBRATOR The spreader mounted vibrator can be activated by pressing and holding the VIB button. When the vibrator function is activated the red LED light next to the VIB button will illuminate. The vibrator function can be configured at set up to operate as momentary, on/off, or as a "timed shutoff".

WORK LIGHT The spreader mounted work light can be configured to automatically operate any time the auger variable speed is set above "0" by connecting the brown wire to the SW LIGHT terminal, connecting to the LIGHT terminal will allow the work light to be controlled by the auxiliary LIGHT button.

AUXILIARY LIGHT The auxiliary light function will operate auxiliary lights with a maximum load of 10 amps. The auxiliary light can be activated by pressing the LIGHT button one time and deactivated by pressing the LIGHT button a second time. When the auxiliary light function is activated the red LED light next to the LIGHT button will illuminate. The auxiliary light function can be configured at set up to operate as momentary, on/off, or as a "timed shutoff".

AUXILIARY EQUIPMENT The auxiliary equipment function will operate auxiliary equipment with a maximum load of 10 amps. The auxiliary equipment can be activated by pressing the AUX button one time and deactivated by pressing the AUX button a second time. When the auxiliary equipment function is activated the red LED light next to the AUX button will illuminate. The auxiliary equipment function can be configured at set up to operate as momentary, on, off, or as a "timed shutoff".

GROUND SPEED The deluxe control system is capable of being operated via the ground speed function at a rate determined by the speed of the vehicle. The ground speed function can be configured during set up to operate as "ground speed triggered" or "ground speed oriented".

When the ground speed function is configured as "ground speed triggered" the auger, spinner, and pre-wet functions will automatically start and stop when the vehicle starts and stops moving. The "triggered" mode does not vary the output rates of the auger, spinner, and pre-wet functions but rather turns them on / off based on the movement of the vehicle.

When the ground speed function is configured as "ground speed oriented" the auger, spinner, and pre-wet speeds will start/stop and increase/decrease at the same rate as the vehicle speed.

The ground speed function can be activated by pressing the GND SPEED button one time, and deactivated by pressing the GND SPEED button a second time. When the ground speed function is activated the red LED light next to the GND SPEED button will illuminate.



Deluxe Spreader Controller



DELUXE CONTROLLER SET UP To enter the configuration mode: Hold press and hold the BLAST button, turn on the controller, and wait for two seconds until the BLAST and PAUSE led lights flash and then release the BLAST button. During the configuration process the flashing LED lights will indicate which value is being set.

A) Set "CONTROL FREQUENCY"

Indication: Both the BLAST and PAUSE LED lights will flash slowly (2 x sec).

Action: Press the AUGER UP button 10 times.

Accept: Press the PAUSE button to accept the setting or the BLAST button to use previous setting.

B) Set "AUGER" MINIMUM TRIM LEVEL

Indication: The BLAST LED light will flash slowly (2 x sec).

Action: Press the AUGER UP button until auger just begins to move.

Accept: Press the PAUSE button to accept the setting or the BLAST button to use the previous setting.

C) Set "AUGER" MAXIMUM TRIM LEVEL

Indication: The BLAST LED light will flash quickly (8 x sec).

Action: Press the AUGER UP button until auger reaches full speed and will not increase.

Accept: Press the PAUSE button to accept the setting or the BLAST button to use the previous setting.

D) Set "SPINNER" MINIMUM TRIM LEVEL

Indication: The PAUSE LED light will flash slowly (2 x sec).

Action: Start auger moving normally (approximately setting "4") and then press the SPINNER UP button until spinner reaches normal speed.

Accept: Press the PAUSE button to accept the setting or the BLAST button to use the previous setting.

E) Set "SPINNER" MAXIMUM TRIM LEVEL

Indication: The PAUSE LED light will flash quickly (8 x sec).

Action: Leave auger moving normally (approximately setting "4") and then press the SPINNER UP button until spinner reaches full speed and will not increase.

Accept: Press the PAUSE button to accept the setting or the BLAST button to use the previous setting.

F) Set "LIQUID" MINIMUM TRIM LEVEL

Indication: The AUX LED light will flash slowly (2 x sec).

Action: Press the LIQUID UP button until liquid just begins to spray.

Accept: Press the PAUSE button to accept the setting or the BLAST button to use the previous setting.

G) Set "LIQUID" MAXIMUM TRIM LEVEL

Indication: The LIQUID LED light will flash quickly (8 x sec).

Action: Press the LIQUID UP button until full flow of liquid is spraying from nozzles and will not increase.

Accept: Press the PAUSE button to accept the setting or the BLAST button to use the previous setting.

Deluxe Spreader Controller

H) Set "BLAST" TIMER

Indication: The BLAST & PAUSE LED lights will flash quickly (8 x sec).

Action: Press the AUGER UP or DOWN buttons until the desired setting is achieved (each mark equals two seconds). To configure blast as on/off set the auger to setting "0".

Accept: Press the PAUSE button to accept the setting or the BLAST button to use the previous setting.

I) Set "GROUND SPEED" MODE

Indication: The BLAST, PAUSE, & LIQUID LED lights will "blip".

Action: Press the SPINNER UP or DOWN buttons until desired setting is achieved (0 = manual only / Ground Speed function is disabled; 5 = Ground Speed "Triggered"; 10 = Ground Speed "Oriented").

Accept: Press the PAUSE button to accept the setting or the BLAST button to use the previous setting.

J) Set "VIBRATOR" FUNCTION

Indication: The VIB LED light will flash slowly (2 x sec).

Action: Press the AUGER UP or DOWN buttons until desired setting is achieved (0 = on/off; 1 = momentary; 2 = delay off). For delay off mode time limit will be set in step M.

Accept: Press the PAUSE button to accept the setting or the BLAST button to use the previous setting.

K) Set "LIGHT" FUNCTION

Indication: The LIGHT LED light will flash slowly (2 x sec).

Action: Press the AUGER UP or DOWN buttons until desired setting is achieved (0 = on/off; 1 = momentary; 2 = delay off). For delay off mode time limit will be set in step M.

Accept: Press the PAUSE button to accept the setting or the BLAST button to use the previous setting.

L) Set "AUX" FUNCTION

Indication: The AUX LED light will flash slowly (2 x sec).

Action: Press the AUGER UP or DOWN buttons until desired setting is achieved (0 = on/off; 1 = momentary; 2 = delay off). For delay off mode time limit will be set in step M.

Accept: Press the PAUSE button to accept the setting or the BLAST button to use the previous setting.

M) Set "DELAY OFF TIME LIMIT" FUNCTION

Indication: The VIB, LIGHT, & AUX LED lights will flash slowly (2 x sec).

Action: Press the AUGER UP or DOWN buttons until desired setting is achieved (each mark equals two seconds; 0 = none).

Accept: Press the PAUSE button to accept the setting or the BLAST button to use the previous setting.



Deluxe Spreader Controller



N) Set "SPINNER LINKED TO AUGER MOVEMENT" FUNCTION

Indication: The VIB, LIGHT, & AUX LED lights will flash quickly (8 x sec).

Action: Press the AUGER UP or DOWN buttons until desired setting is achieved (0 = spinner will not operate at minimum speed when auger is turning; 1 = spinner will operate at minimum speed when auger is turning). When configured to setting "1" spinner will always operate at setting "1" when auger is turning to keep the discharge chute clear.

Accept: Press the PAUSE button to accept the setting or the BLAST button to use the previous setting.

O) CONFIGURATION IS COMPLETE

Indication: The PAUSE & BLAST LED lights will flash in an alternating pattern (left; right; left; right).

Action: Cycle power to exit configuration mode. To cycle the power turn the ON/OFF switch to the "OFF" position, and then to the ON position.

TESTING SIGNAL OUTPUTS

1. Start vehicle and power on controller by moving the ON/OFF switch to the "ON" position.
2. Deactivate the GROUND SPEED function and set the AUGER speed to any non-zero setting. The auger should be turning.
3. Activate the GROUND SPEED function by pressing the GND SPEED button. The auger should stop turning.

4. Drive vehicle slowly forward. Verify auger begins to turn when vehicle exceeds 2 mph. If auger does not operate adjust the SPEEDO reference trim pot on the back of the controller until the auger responds to vehicle motion.
5. Final trimming of the AUGER function can be accomplished after the ground speed signal is validated.
6. To adjust one or more trim settings, hold the BLAST button, turn the ON/OFF switch to the "ON" position, wait for two seconds and then release the BLAST button. The controller will now enter the configuration mode as before. You can select certain settings to change by cycling through the configuration mode by pressing the BLAST button to use the previous settings. To accept new settings, press the PAUSE button after making adjustments.

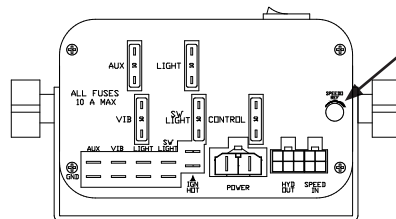

Deluxe Controller
Rear View

Standard Spreader Controller

Standard Spreader Controller allows each electric motor to be independently controlled. Controller consists of the following functions: on/off, dual variable speed control, and a blast feature.

OPERATION When controller ON/OFF switch is in the “OFF” position, the controller has no functions and spreader will not operate. When ON/OFF switch is in the “ON” position, the controller functions are able to be used and spreader can operated. When controller is on green LED lights will illuminate over variable speed dials.

AUTO-BLAST FEATURE Each time the controller is turned on, the auto-blast feature will start automatically. The auto-blast feature will automatically increase the speed of both electric motors to setting “8” for three seconds. After three seconds the electric motor speeds will return to the speed as set on the dials. The auto-blast feature is intended to clear any material jams that may have occurred when transporting the spreader.

VARIABLE SPEED SETTINGS Controller is equipped with dual variable speed dials, one each for the auger and spinner electric motors. Variable speed dials have setting of 0 – 10 with setting 10 being full speed. NOTE: depending upon the weight of material on the auger or spinner, electric motors may not operate at lower dial settings.

BLAST FEATURE Controller is also equipped with a blast feature. The blast feature allows for momentary high output spreading. When the BLAST button is depressed, yellow LED will illuminate and auger and spinner speeds will automatically increase to setting “8”, when BLAST button is released, auger and spinner will return to speed set on variable speed dials.

JAM / OVERLOAD MODE Controller is equipped with a jam and overload feature. When amperage required by electric motors exceeds the safe level the controller will enter the overload function. The overload function will reduce the amperage to a safe level. Overload mode can be identified by the illumination of the red flashing LED marked OVERLOAD. If overload function is unable to clear obstruction, controller will enter the jam mode which will be indicated by the illumination of the red LED marked JAM. When controller enters the jam mode, all functions of the controller will stop to protect electrical system from damage. Once the obstruction is cleared the controller will need to be switched off and then back on to clear jam mode before operation can resume.

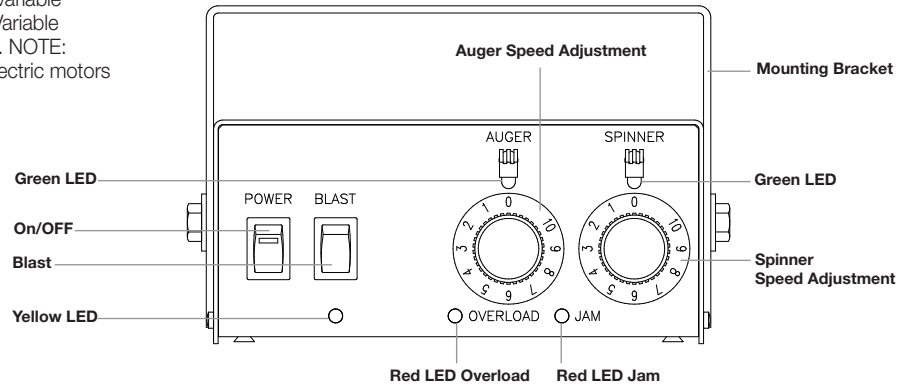

Operating Instructions

Filling Hopper

The hopper should only be filled with clean, dry, free-flowing rock salt. Commercial bagged ice melt materials may be used. Spreader is not designed to spread ag lime, gravel, rock, cinders, or any other aggregate materials. Only fill the hopper with the top screen installed to prevent foreign objects or frozen clumps of material from entering the hopper and damaging the conveyor system. Do not leave unused material inside of hopper when not in use. Do not let material freeze inside of hopper.

Gearbox: Never apply torque to output shaft of gearbox. Gearbox is designed to only accept torque from the input shaft.

Engaging Conveyor: To prevent premature wear of the electric clutch, roller chain and v-belt, engine throttle speed should be lowered to idle before engaging electric clutch.

Electric Clutch: To achieve maximum torque, new electric clutches should be burnished prior to the first use. Refer to the maintenance section of this manual for clutch burnishing procedure.

Transporting Spreader: It is recommended to turn off the fuel to the engine when transporting spreader without the engine running.

Swing-up Spinner: Do not transport spreader with the spinner in the up position.

Regulating amount of material being spread

The amount of material being spread depends upon the auger speed. Increasing the auger speed will increase the amount of material being spread. Decreasing the auger speed will decrease the amount of material being spread.

The auger speed can be adjusted on the deluxe spreader controller by pressing the AUGER UP or DOWN buttons until the desired speed is achieved.

The auger speed can be adjusted on the standard spreader controller by turning the AUGER knob left or right until the desired auger speed is achieved.

Regulating the spread pattern

The spread pattern is the width and direction of material being spread. The width of the spread pattern can be regulated by increasing or decreasing the spinner disc speed. Increasing the spinner disc speed will increase the spread width. Decreasing the spinner disc speed will decrease the spread width. The direction of the spread pattern can be regulated by adjusting the external baffles on the spinner assembly.

The spinner speed can be adjusted on the deluxe spreader controller by pressing the SPIN UP or DOWN buttons until the desired speed is achieved.

The spinner speed can be adjusted on the standard spreader controller by turning the SPINNER knob left or right until the desired speed is achieved.

Adjusting external spinner baffles:

1. Loosen wing both wing nuts on each spinner baffle.
2. Slide spinner baffles in or out to desired position.
3. Tighten wing nuts on both spinner baffles.



Noise & Vibration Reduction

To reduce the amount of noise and vibration produced by the spreader:

1. Keep all mechanical fasteners and guards tight and in their proper location.
2. Periodically clean built-up material from spinner disc.
3. Use optional hopper vibrator only as needed.
4. Only spread clean material free of debris such as rocks, wood, asphalt, etc.

Operating Instructions

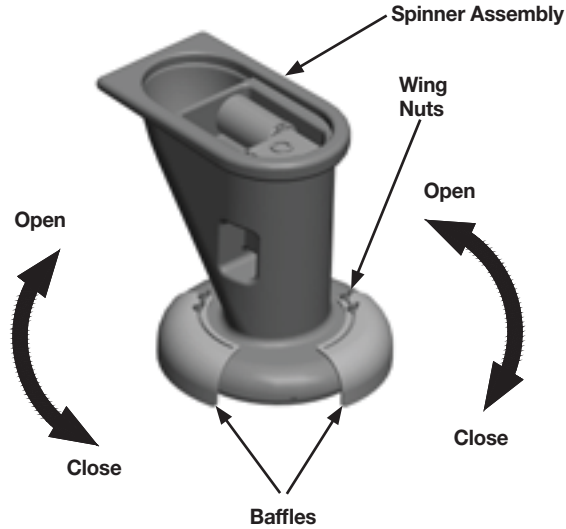
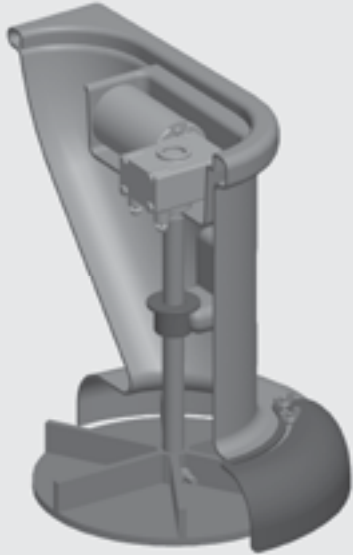

DESIRED SPREAD PATTERN	BAFFLE SETTING	
	LEFT	RIGHT
LEFT & RIGHT	OPEN	OPEN
LEFT	OPEN	CLOSED
RIGHT	CLOSED	OPEN
CENTER WINDROW	CLOSED	CLOSED

Operating Instructions

Left Spread Pattern

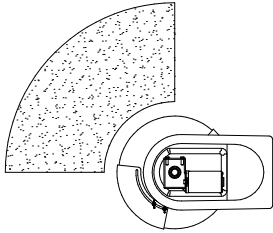

Left & Right Pattern

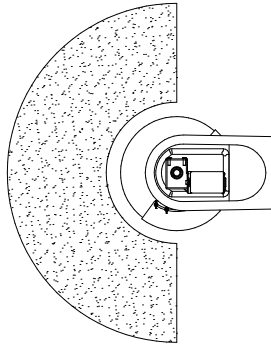

Windrow Spread Pattern

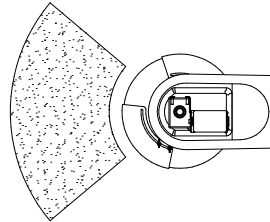

Right Spread Pattern

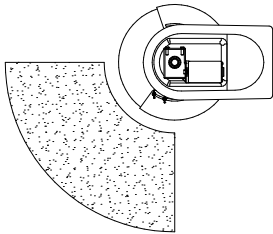

Electrical Schematics

Wiring schematic for the Standard Crossfire Spreader.

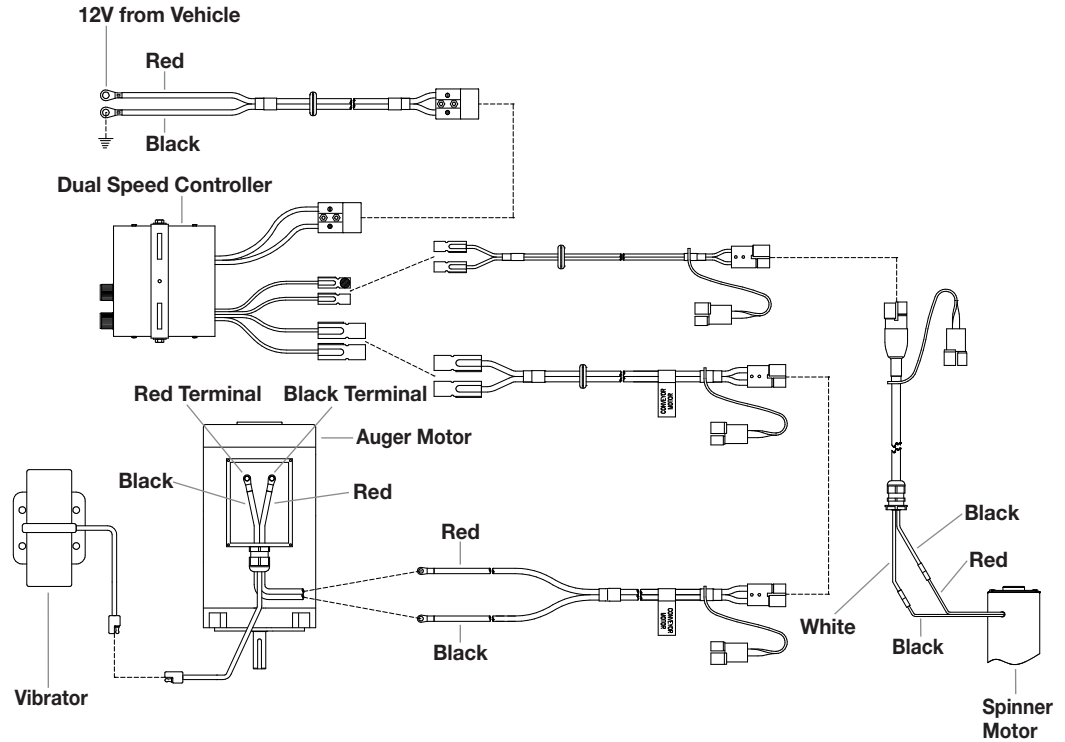

Electrical Schematics

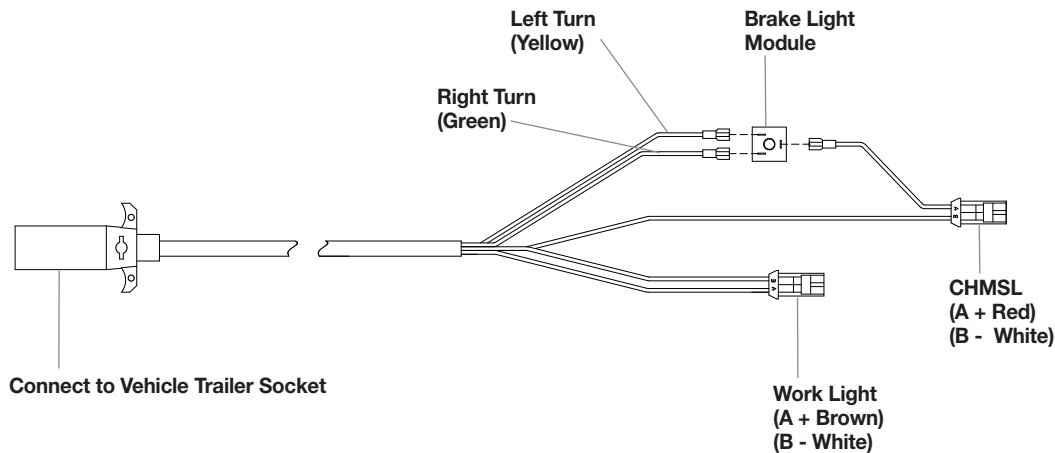

Wiring schematic for the Standard Crossfire Spreader.

Electrical Schematics

Wiring schematic for the
Deluxe Crossfire Spreader.

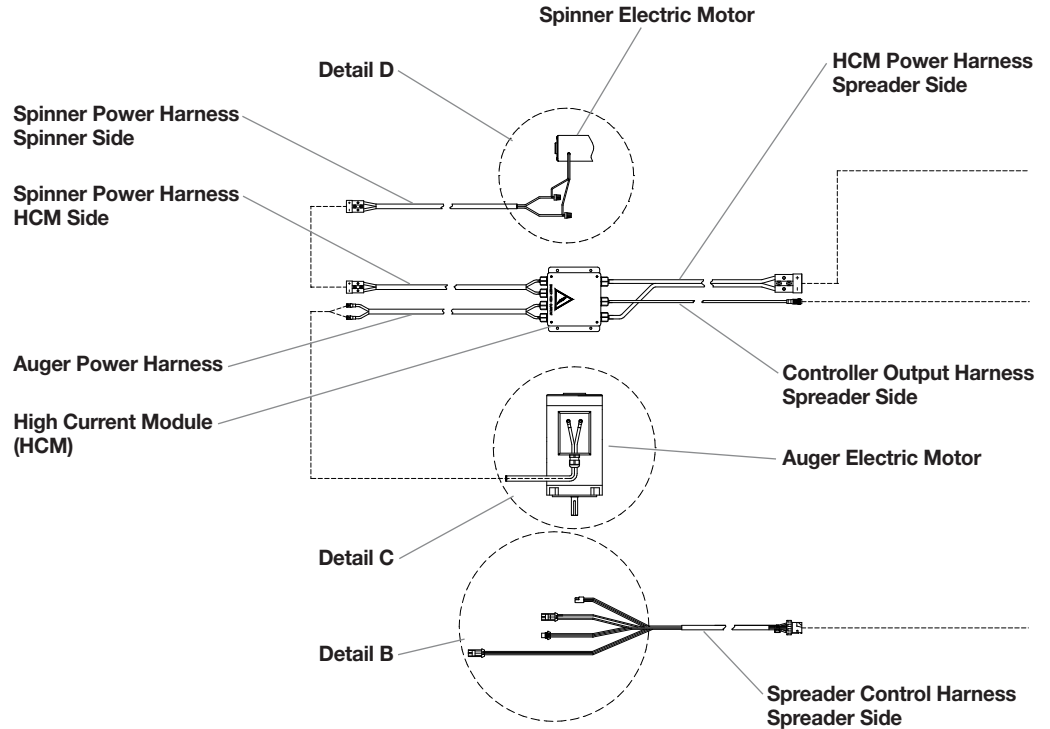

Electrical Schematics

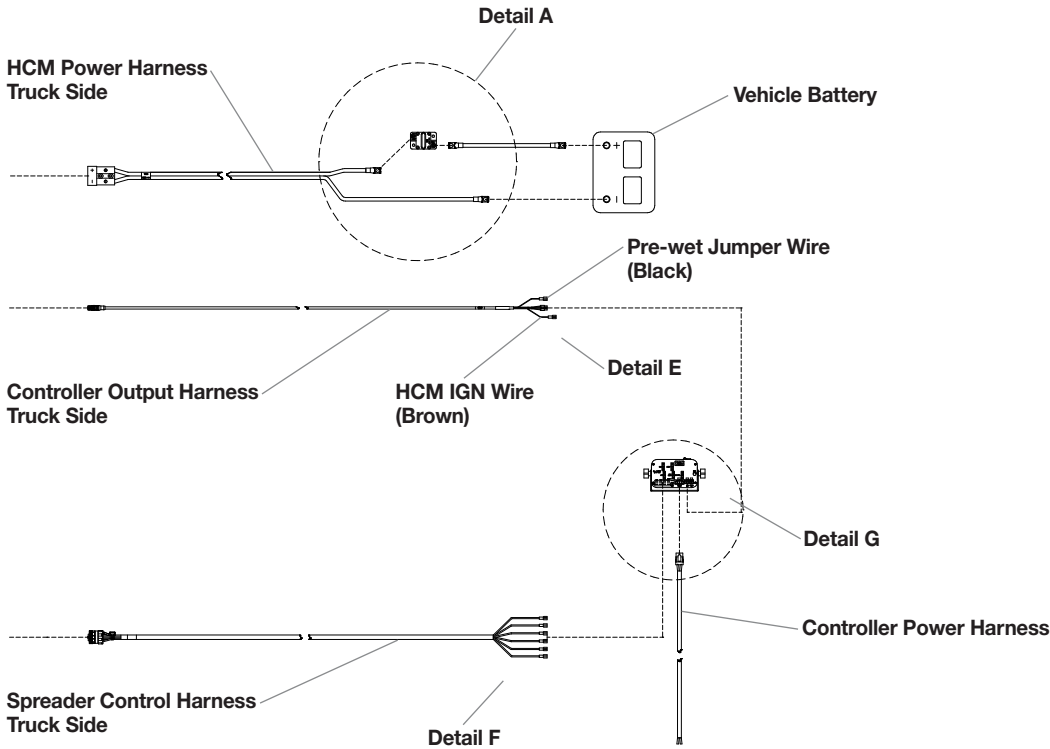

Wiring schematic for the Deluxe Crossfire Spreader.

Electrical Schematics

Wiring schematic for the Deluxe Crossfire Spreader.

Detail A

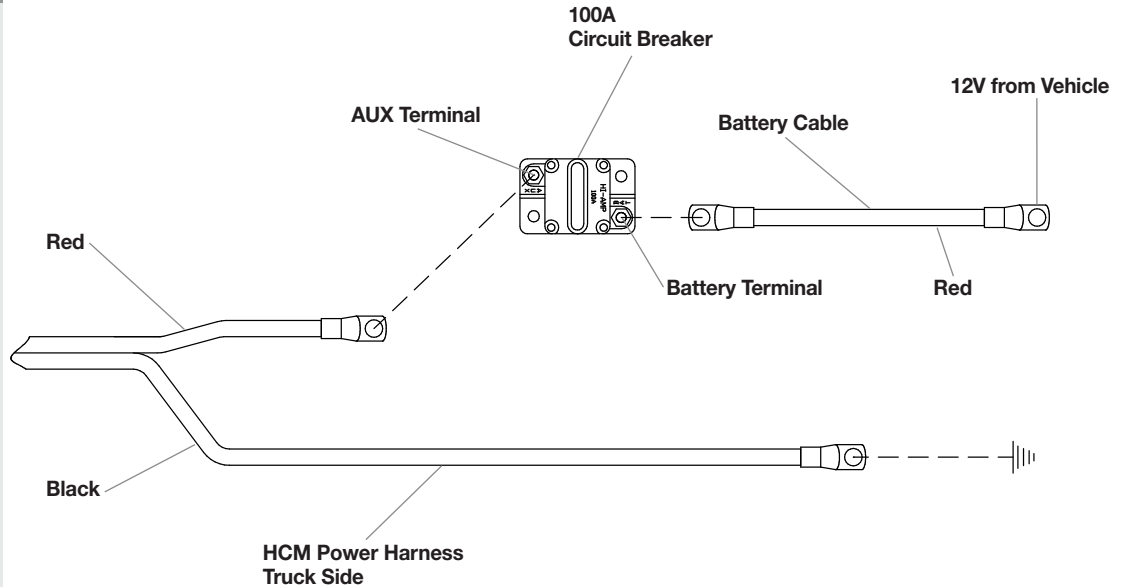

Wiring schematic for the
Deluxe Crossfire Spreader.

Detail B

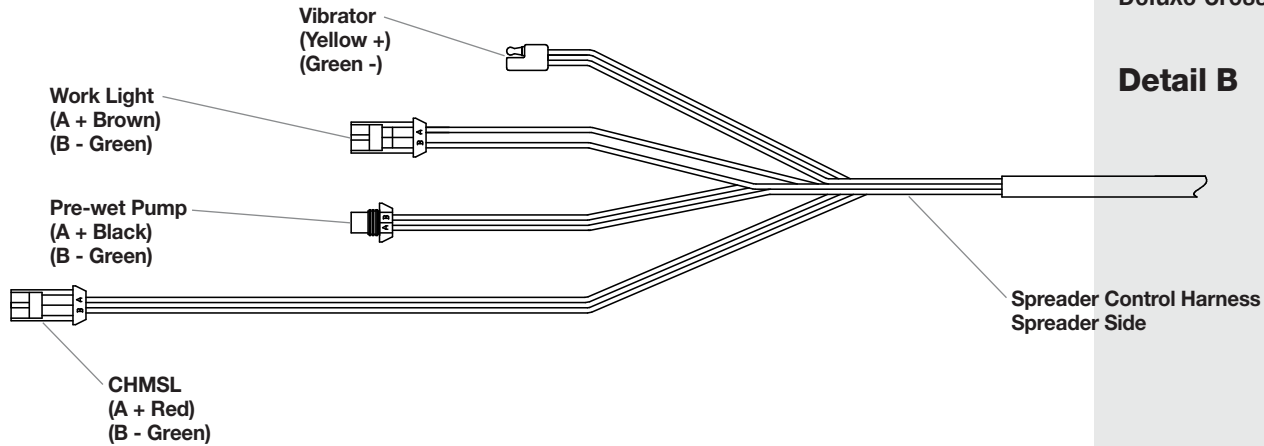

Electrical Schematics

Wiring schematic for the
Deluxe Crossfire Spreader.

Detail C

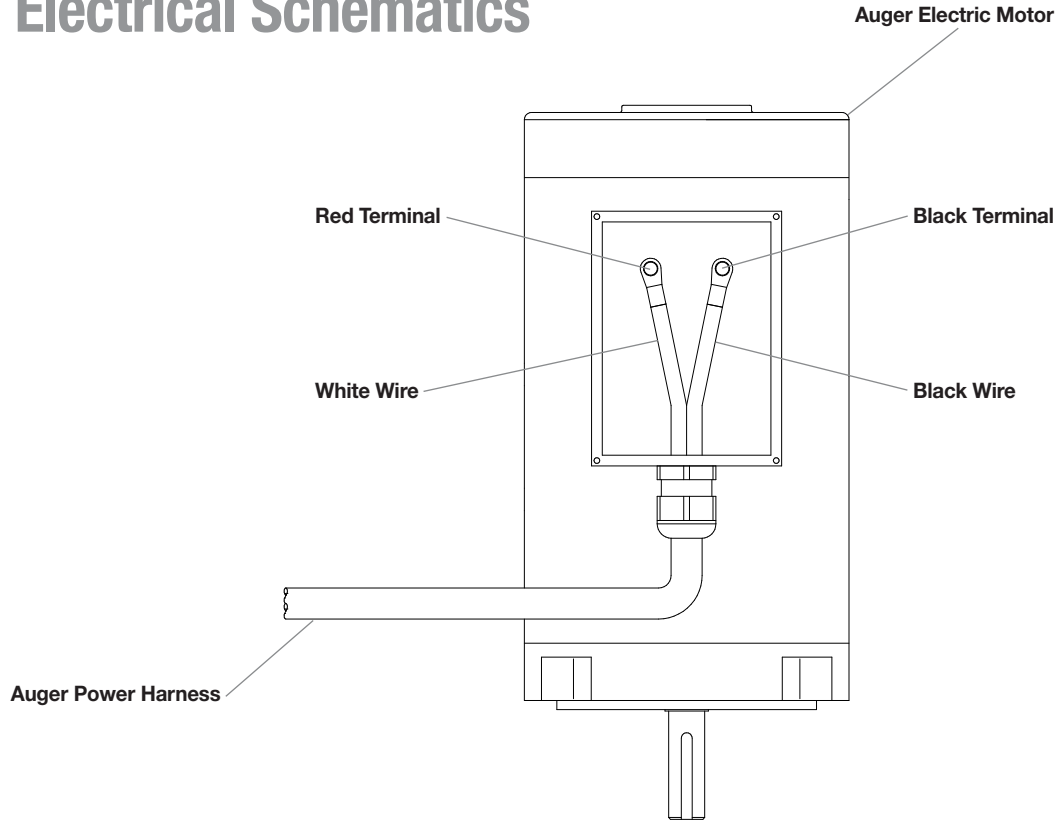

Electrical Schematics

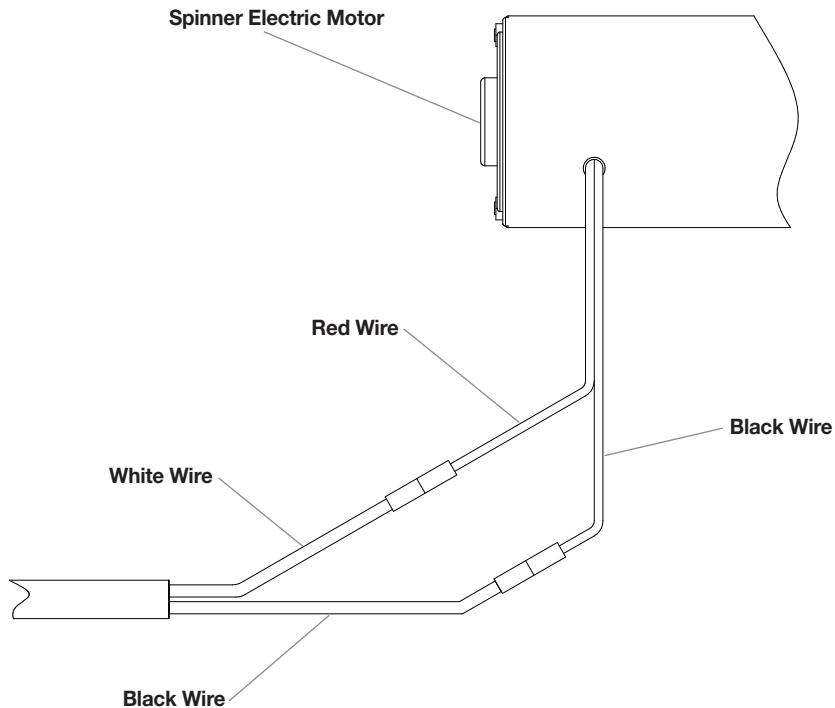

Wiring schematic for the
Deluxe Crossfire Spreader.

Detail D

Electrical Schematics

Wiring schematic for the
Deluxe Crossfire Spreader.

Detail E

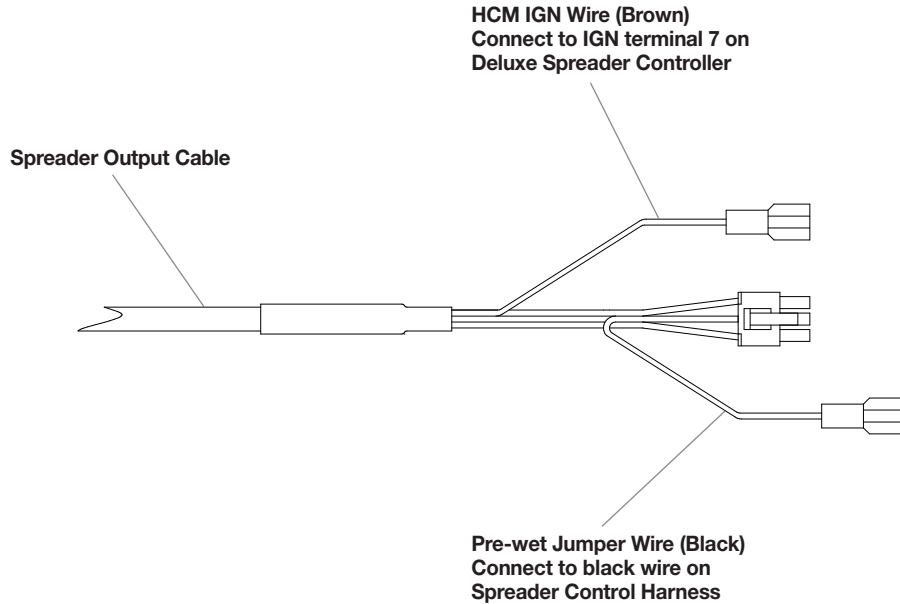

Electrical Schematics



Wiring schematic for the
Deluxe Crossfire Spreader.

Detail F

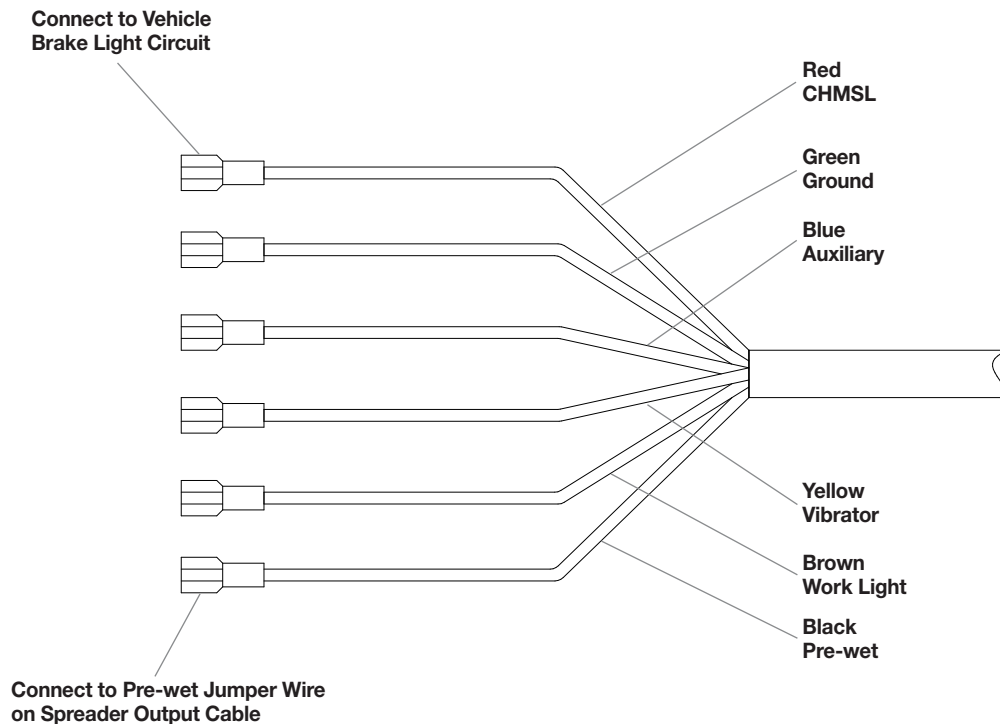

Electrical Schematics

Deluxe Spreader Controller Rear View

Wiring schematic for the
Deluxe Crossfire Spreader.

Detail G

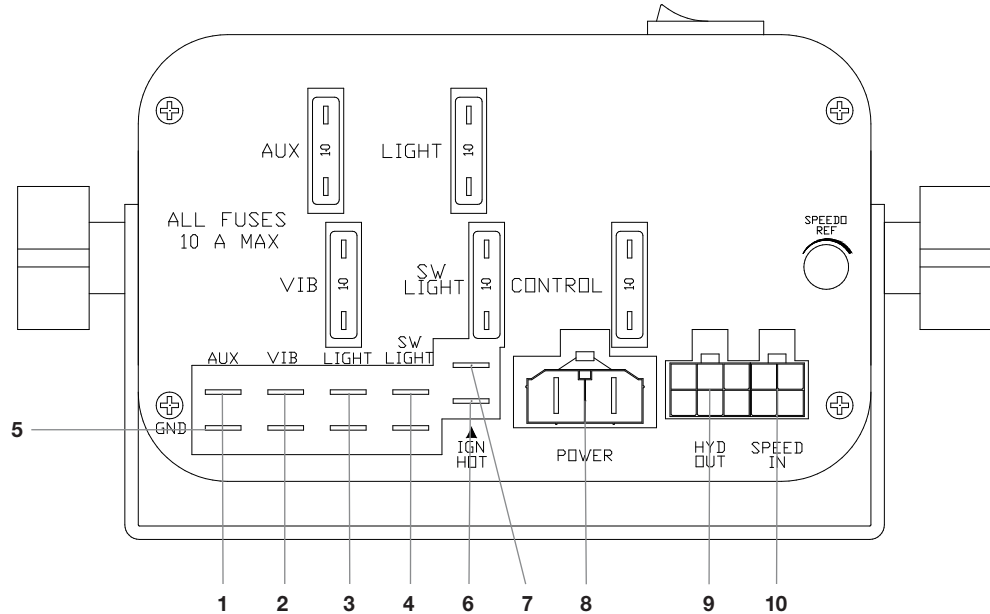

Electrical Schematics



Deluxe Spreader Controller Wire Connections

Terminal	Harness	Wire Color	Function
1	Spreader Control Harness	Blue	Aux
2	Spreader Control Harness	Yellow	Vibrator
3	Spreader Control Harness	Brown *	Work Light
4	Spreader Control Harness	Brown *	Work Light
5	Spreader Control Harness	Green	Ground
6	12V from vehicle ignition	Red **	
7	HCM IGN (Spreader Output Cable)	Brown	
8	Controller Power Harness	Black / White	
9	Spreader Output Cable	Yellow	
10	Ground Speed Cable	Black / White	

* To control the work light with the "LIGHT" button, connect the brown wire to terminal 3 - LIGHT.
To allow work light to automatically operate with auger, connect brown wire to terminal 4 - SW LIGHT.

** Red ignition wire to be connected from terminal 6 - IGN to 12V ignition circuit on vehicle.

Connect black wire from Spreader Control Harness to Pre-wet Jumper Wire on Spreader Output Cable (see Detail F).

Wiring schematic for the Deluxe Crossfire Spreader.

Detail G

Maintenance

Regular maintenance is the key to your Meyer Spreader operating efficiently and trouble free. Meyer Products LLC recommends this maintenance information for regular service. Sustained heavy operation may call for more frequent service. Material spreading subjects a vehicle to exceptionally rugged use. As a result, it is very important to inspect and bring the spreader and vehicle up to maximum operating conditions. Inspection should be made of both the vehicle and spreader prior to the winter season and each use.

Pre-Season Maintenance

Scheduled vehicle maintenance should be performed as recommended by the manufacturer.

Vehicle Maintenance

Don't forget that in addition to keeping equipment in order:

1. Keep windshield wipers, heaters and lights working.
2. Use emergency flashing lights for increased visibility and safety.
3. Equip vehicle with tire chains when necessary.
4. Provide operators with protective clothing and gloves for handling ice melting chemicals.

Vehicle Electrical System

For maximum efficiency, the vehicle supporting the spreader must be properly serviced. The system should consist of at least a 70 amp/hr battery and a 60 amp alternator. Be sure to check regularly:

1. Battery terminals to assure they're tight and free of corrosion.
2. Electrical connections, to assure they're tight and corrosion free.
3. Battery must be in top operating condition.
4. Alternator and regulator, to assure maximum electrical output.

Vehicle Hydraulic System

To prevent any issues with the vehicle hydraulic system, be sure to perform the following prior to the winter season:

1. Flush and refill hydraulic reservoir. Replace hydraulic oil filter.
2. Inspect hydraulic pump, motors, hoses, and couplers for damage or leaks.
3. Refer to hydraulic pump manufacturers maintenance recommendations.

Spreader

Prior to the start of the winter season the pre-season maintenance should be performed to ensure the spreader operates reliably. Follow the maintenance schedule for service recommendations. Don't forget to also do the following:

1. Verify spreader is securely attached to vehicle.
2. Inspect Spreader for loose, missing, or damaged parts, guards, or hardware.
3. Repaint any rusty parts.
4. Ensure moving parts are free and not corroded.
5. Test run spreader before filling with material.



Maintenance



General Maintenance

Inspection: Before and after each use, spreader should be inspected for loose, missing, or damaged mounting hardware, parts, or safety guards. Spreader should also be inspected to ensure it is securely attached to the vehicle.

Cleaning: Empty all material from spreader after each snow or ice event. Wash entire spreader with soap and warm water. Do not clean spreader with any corrosive chemicals or products that contain chlorides or ammonium. Any commercially available salt neutralizer may be applied.

Gearbox: Both the auger and spinner gear reducers are permanently sealed for life and do not require lubrication.

Electrical System: Electrical system should be inspected for loose connections and corrosion every 10 hours of operation or weekly. Dielectric grease should be applied to all electrical connections.

Post Season Maintenance

At the end of the winter season, perform the post-season maintenance as listed in the maintenance service schedule to prevent costly repairs at the start of the next season. Also don't forget to:

1. Empty and thoroughly wash entire spreader with warm soap and water.
2. Apply dielectric grease to all electrical connections and install connector covers to prevent corrosion.
3. Oil or paint any rusty parts or surfaces.

Maintenance Service Schedule

MAINTENANCE TASK TO BE COMPLETED	Pre-Season	Daily	10 Hours or Weekly	Post-Season
Inspect spreader for loose, missing, or damaged parts or hardware	X	X		X
Verify spreader is securely attached to vehicle	X	X		
Inspect electrical connections and apply dielectric grease to connections	X		X	X
Oil or paint rusty surfaces	X			X

Troubleshooting Guide

General Troubleshooting

Condition	Possible Cause	Correction
Auger will not operate	Standard controller not functioning properly	See standard controller troubleshooting
	Deluxe controller not functioning properly	See deluxe controller troubleshooting
	Auger jammed by a foreign object, or frozen material	Inspect auger for obstruction and remove
	Damaged gearbox	Inspect and repair gearbox
	Shaft key missing from auger motor	Inspect for missing key and replace
Auger operates erratically	Shaft key missing from auger motor	Inspect for missing key and replace
	Material "bridged over" in hopper	Replace with clean, dry, free flowing material
Noisy operation	Loose or damaged auger	Adjust or replace auger
	Foreign object in auger	Remove object
	Spinner disc unbalanced	Remove material from spinner disc
Material not exiting discharge chute	Auger discharge clogged	Clear material from discharge
	Material "bridging" inside hopper	Use free flowing material
	Inverted Vee not installed	Install inverted Vee
Material leaking from hopper	Material too fine	Use a coarser material
Spinner disc not turning	Spinner disc jammed	Clear jam from spinner disc
	Shaft roll pin missing	Inspect and replace roll pin



Troubleshooting Guide



Standard Controller Troubleshooting

Condition	Possible Cause	Correction
Controller has no power	Controller not turned ON	Move on/off switch to on
	Power supply harness connections loose or corroded	Clean and tighten power supply harness connections
	Controller internal fuse blown	Replace internal fuse
Controller has power but auger does not operate	Auger harness is not connected to controller	Connect auger harness to controller
	Auger harness connection at rear bumper is loose or corroded	Clean and reconnect auger harness connections
	Auger harness connections at electric motor are loose or corroded	Clean and tighten auger harness connections
	Auger speed setting is set too low	Adjust auger speed to a higher setting
	Controller internal fuse blown	Replace fuse
	Auger harness damaged	Replace auger harness
Controller has power but spinner does not operate	Spinner harness is not connected to controller	Connect spinner harness to controller
	Spinner harness connection at rear bumper is loose or corroded	Clean and reconnect spinner harness connection
	Spinner harness connections at electric motor are loose or corroded	Tighten or replace spinner harness wire nuts
	Spinner speed setting is set too low	Adjust Spinner speed to a higher setting
	Controller internal fuse blown	Replace fuse
	Spinner harness damaged	Replace spinner harness
Auger operates erratically	Loose or corroded auger harness connections	Clean and tighten harness connections
	Auger speed setting is set too low	Adjust auger speed to a higher setting
	Defective electric motor	Replace electric motor
	Auger harness damaged	Replace auger harness



Troubleshooting Guide

Standard Controller Troubleshooting (continued)

Condition	Possible Cause	Correction
Spinner operates erratically	Loose or corroded spinner harness connections	Clean and tighten harness connections
	Spinner speed setting is set too low	Adjust spinner speed to a higher setting
	Defective electric motor	Replace electric motor
	Spinner harness damaged	Replace spinner harness



Troubleshooting Guide

Deluxe Controller Troubleshooting

Condition	Possible Cause	Correction
Controller has no power	Controller not turned ON	Move on/off switch to on
	Power supply harness connections loose or corroded	Clean and tighten power supply harness connections
	Controller fuse blown	Replace fuse
Controller has power but auger does not operate	Auger harness is not connected to HCM	Connect auger harness to HCM
	Auger harness connection at HCM is loose or corroded	Clean and reconnect auger / HCM harness connections
	Auger harness connections at electric motor are loose or corroded	Clean and tighten auger harness connections
	Auger speed setting is set too low	Adjust auger speed to a higher setting
	HCM internal fuse blown	Replace fuse
	Auger harness damaged	Replace auger harness
Controller has power but spinner does not operate	Spinner harness is not connected to HCM	Connect spinner harness to HCM
	Spinner harness connection at HCM is loose or corroded	Clean and reconnect spinner / HCM harness connection
	Spinner harness connections at electric motor are loose or corroded	Tighten or replace spinner harness connections
	Spinner speed setting is set too low	Adjust Spinner speed to a higher setting
	HCM internal fuse blown	Replace fuse
	Spinner harness damaged	Replace spinner harness
Auger operates erratically	Loose or corroded auger harness connections	Clean and tighten harness connections
	Auger speed setting is set too low	Adjust auger speed to a higher setting
	Defective electric motor	Replace electric motor
	Auger harness damaged	Replace auger harness



Troubleshooting Guide

Deluxe Controller Troubleshooting (continued)

Condition	Possible Cause	Correction
Spinner operates erratically	Loose or corroded spinner harness connections	Clean and tighten harness connections
	Spinner speed setting is set too low	Adjust spinner speed to a higher setting
	Defective electric motor	Replace electric motor
	Spinner harness damaged	Replace spinner harness

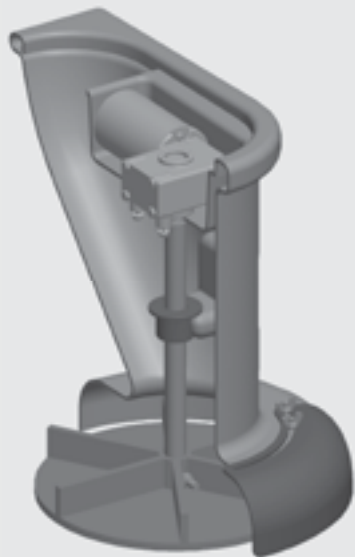

Meyer® One Year Spreader Warranty



Meyer Products warrants to the original purchaser only that it will repair, or at the sole option of Meyer Products replace any part of this Meyer Spreader or Spreader accessory which proves to be defective in workmanship or material under normal use for its intended purpose, that being spreading material, for a period of one year from the date of delivery. This warranty is not transferable or assignable. The original purchaser's sole and exclusive remedy against Meyer Products and Meyer Products' sole obligation for any and all claims, whether for breach of contract, warranty, tort (including negligence) or otherwise shall be limited to providing, through its authorized Distributor/Sub-Distributor network, all labor and/or parts necessary to correct such defects free of charge. Any cost incurred in returning the product to the Distributor/Sub-Distributor is the responsibility of the consumer. The gasoline engine used in the Insert Hopper Spreaders is covered by its own warranty as provided by the engine manufacturer. A copy of this warranty is included with the engine.

Warranty Service

In order to obtain service under this warranty, the original purchaser must return the claimed defective part to the Distributor/Sub-Distributor from whom the product was purchased or to any authorized Meyer Distributor/Sub-Distributor, transportation and freight charges prepaid. Only Meyer Distributors/Sub-Distributors are authorized to perform the obligations under these warranties. For the address and telephone number of the Distributor/Sub-Distributor nearest you, check the telephone directory or you may write to Meyer Products at the address below.

General

It is the responsibility of the original purchaser to establish the warranty period by verifying the original delivery date. A bill of sale, cancelled check or some other appropriate payment record may be kept for that purpose. It is recommended, but not required, that the consumer verify by immediately returning the attached Warranty Registration Card. No person is authorized to change this warranty or to create any warranty other than that set forth herein. This warranty gives you specific legal rights and you may also have other rights which vary from state to state.

Exclusions

This warranty does not cover paint or expendable spreader parts such as pins, spreader fins and other normal wear items. Meyer Products shall not be liable for any special, indirect or consequential damages arising hereunder, or for damages resulting from lack of necessary maintenance, from misuse, abuse, acts of god, alteration of a Meyer Spreader or part, or from use of parts or hydraulic fluid not supplied by Meyer Products. Use of the Meyer Spreader for any purpose other than spreading the recommended materials is one example of an abuse and misuse of the product.

The foregoing warranty is exclusive and in lieu of all warranties, express or implied, including, but not limited to, any implied warranty of merchantability or fitness for a particular purpose.



Meyer offers a complete line of spreaders for any application and vehicle size. Go to www.MeyerProducts.com for more information.

Dealer/Distributor:



Meyer Products, LLC
18513 Euclid Avenue
Cleveland, Ohio 44112

216-486-1313

www.meyerproducts.com